

Siemens Traffic Controls,
Sopers Lane,
Poole,
Dorset,
BH17 7ER

SYSTEM/PROJECT/PRODUCT : METEOR Responder

METEOR Telephone Responder Manual

(Stores Code - Manual 0532 1 SPC)

Prepared : P. Hall

Function : Designer

THIS DOCUMENT IS ELECTRONICALLY APPROVED
AND HELD IN AMW

Issue :	Change Ref. :	Date :
1	First Issue	22/10/2003
2	Second Issue	15/11/2006

© Crown Copyright 2003

Product Support

Technical support is provided by STC Engineering for the benefit of the Highways Agency and its installation and maintenance contractors. Technical support is provided for the items included in the Installation, Commissioning and Maintenance sections of this Manual.

The Telephone Help Line is available between the hours of 9.00 am and 5.00 pm, Monday to Friday (excluding Bank Holidays). Outside office hours use the Fax Help Line.

Telephone: (01202) 782188

Fax: (01202) 782545

Dave Martin, Engineering Manager, Product Development.

Siemens Traffic Controls

Sopers lane

Poole

Dorset

BH17 7ER

SAFETY WARNINGS

In the interests of health and safety, when using or servicing this equipment the following instructions must be noted and adhered to:

- (i) Only instructed personnel with relevant technical knowledge and experience, who are also familiar with the safety procedures required when dealing with modern electrical/electronic equipment are to be allowed to use and/or work on the equipment. All work shall be performed in accordance with the Electricity at Work Regulations 1989.
- (ii) Such personnel must take heed of all relevant notes, cautions and warnings in this manual, and any other document or manual associated with the equipment including, but not restricted to, the following:
 - (a) The equipment must be correctly connected to the specified incoming Power Supply.
 - (b) In general, the equipment must be disconnected/isolated from the incoming Power Supply before removing protective covers or working on any part from which protective covers have been removed. Refer to specific instructions contained within this document for details.
 - (c) The equipment contains batteries, which must be disposed of in a safe manner. If in doubt of the correct procedure refer to Siemens procedure 237/RE/00357/000 (contained within the Health & Safety Manual).
 - (d) The equipment must not be installed or removed with the batteries installed. The batteries constitute the majority of the weight of the equipment. Failure to observe this precaution could result in serious injury to personnel and damage to the equipment.

TELECOMMUNICATIONS APPROVAL WARNING

The NMCS2 METEOR Telephone Responder 667/1/30500/000, is approved for direct connection to UK Speechband Private Circuits in both a 2-wire point-to-point and a 4-wire point-to-point configuration as defined in CTR 15 and CTR17 subject to the conditions set out in the instructions for use.

Unless otherwise stated, all the conditions stated apply to this type of apparatus.

It is NOT suitable for connection to the PSTN or to circuits with signalling at a nominal frequency of 2280 Hz. It is not intended that there shall be any DC interaction between this apparatus and UK private circuits, nor does this apparatus use the frequency range DC to 200Hz.

Connection to the private circuit is by means of a 12/24-way Klippon type BKST socket (not supplied), which mates with the 12/24-way Klippon type BKST plug supplied as part of the METEOR Responder. This method of connection is the responsibility of the public telecommunications operator or a person authorised by that operator. The connection cable must comply with a code of practice for the installation of equipment covered by CTR 15 and CTR17 or such other requirements as may be applicable.

WARNING: Interconnection directly, or by way of other apparatus, of telephone connection ports or ports marked in accordance with BS EN 41003 : 1993 with ports marked or not so marked may produce hazardous conditions on the network and advice should be obtained from a competent engineer before such a connection is made.

Prevention of access by user: This apparatus is intended to be accessible only to authorised personnel. This apparatus must be installed in a locked cabinet or similar environment, such that user access is prevented. Failure to prevent such user access will invalidate any approval given to this apparatus. This apparatus does not require installation and operation under conditions of controlled ambient temperature and is capable of operation at levels of relative humidity above 60%. The approval of this equipment for connection to UK Speechband Private circuits is INVALIDATED if the apparatus is subject to any modification in any material way not authorised by BABT or it is used with internal software that has not been formally accepted by BABT.

All apparatus connected to this equipment and thereby connected directly or indirectly to UK Private Speechband circuits must be approved apparatus as defined in Section 16 of the British Telecommunications Act 1981. This equipment makes use of signals close to 2700Hz and may cause miss-operation of the automatic test facilities provided by the public telecommunications operator (PTO). If the normal operation of the circuit causes false operation of the automatic equipment, the PTO will remove that automatic test equipment from the circuit.

The circuit must be terminated in 600 or 1200 ohms at, or near to, the point of connection to the METEOR Responder equipment. The circuit should also be terminated in the same value resistor at the distant end of the circuit, if such termination is not already included in the equipment connected to the distant end (See Section 3.3.8).

Telephones to be connected to the Responder should be either previously approved or be compliant with BS6328 Part 1:1985 clauses 4 to 9 or be compliant with BS6317:1982.

This manual must be supplied with the apparatus. The validity of the approval depends on this information being supplied.

CONTENTS

1	<u>ABOUT THIS MANUAL</u>	8
1	<u>ABOUT THIS MANUAL</u>	8
1.1	WHAT IS COVERED	8
1.2	HOW TO FIND YOUR WAY AROUND	8
1.3	GLOSSARY	8
2	<u>EQUIPMENT DESCRIPTION</u>	9
2.1	OVERVIEW	9
2.2	PHYSICAL ARRANGEMENT	11
2.3	POWER SUPPLIES	12
2.4	PCBS	13
2.4.1	PROCESSOR PCB	13
2.4.2	BACKPLANE PCB	15
2.4.3	TELEPHONE INTERFACE PCB	16
2.4.4	LINE PROTECTION PCBS	18
2.5	EQUIPMENT OPERATION	19
2.5.1	FOLLOWING POWER-UP AND RESET	19
2.5.2	DURING NORMAL OPERATION	19
2.5.3	TELEPHONE TESTING	20
3	<u>INSTALLATION</u>	21
3.1	SAFETY PRECAUTIONS	21
3.2	PRE-INSTALLATION CHECKS	21
3.3	INSTALLATION OF THE UNIT INTO THE CABINET	21
3.3.1	PREPARATION OF THE RESPONDER	21
3.3.2	PREPARATION OF THE BATTERY UNIT	22
3.3.3	INSTALLATION OF THE RESPONDER AND BATTERY UNIT	22
3.3.4	INSTALLATION OF BATTERIES	24
3.3.5	CONFIGURATION OF SWITCHES	25
3.3.6	INSTALLATION OF POWER SUPPLIES	30
3.3.7	INSTALLATION OF CABLES	31
3.3.8	TERMINATION OF CABLES	32
3.3.9	APPLYING POWER	33
3.3.10	COMMISSIONING	34
4	<u>MAINTENANCE</u>	36
4	<u>MAINTENANCE</u>	36
4.1	SAFETY PRECAUTIONS	36
4.2	ROUTINE MAINTENANCE PROCEDURE	36
4.2.1	SAFETY CHECKS	36
4.2.2	REPLACEMENT OF BATTERIES.	36

4.3	FAULT FINDING	38
4.3.1	MONITOR LEDS	39
4.3.2	MONITOR JACK	40
4.4	EMERGENCY MAINTENANCE PROCEDURE	41
4.4.1	REPLACEMENT OPERATIONS WITH POWER REMOVED	41
4.4.2	REPLACEMENT OPERATIONS WITH POWER APPLIED	41
4.5	RECOMMENDED SPARES	43
4.5.1	PCBS AND OTHER MAJOR ASSEMBLIES	43
4.5.2	FUSES	43
4.5.3	LINE PROTECTION CARD FUSE REPLACEMENT	43
5	RECONFIGURING THE RESPONDER	44
5.1	CHANGING THE CONNECTION CHARACTERISTICS	44
5.2	CHANGING THE RESPONDER ADDRESS	46
5.3	CHANGING THE NUMBER OF TELEPHONES CATERED FOR	47
6	USE OF THE MAINTENANCE TERMINAL	49
6.1	MAINTENANCE TERMINAL CONNECTION	49
6.2	HOW TO USE THE TERMINAL	49
6.3	INTERPRETING THE CALL STATUS DISPLAY.	51
6.4	INTERPRETING THE PSU STATUS DISPLAY	53
6.5	INTERPRETING THE CPU STATUS DISPLAY.	54
6.6	INTERPRETING THE EVENT LOG	55
6.7	INTERPRETING THE CONFIGURATION DISPLAY	57
6.8	MODEM TONE DISPLAY	58
6.9	OTHER TEST FACILITIES	58
7	TECHNICAL SPECIFICATION	59
7.1	PHYSICAL CHARACTERISTICS	59
7.2	GENERAL ELECTRICAL CHARACTERISTICS	59
7.3	COMMUNICATIONS CHARACTERISTICS	60
7.4	MAINTENANCE TERMINAL	61
7.5	TOOL LIST	62
7.6	PRODUCT END OF LIFE PLAN	62
	SUBJECT AND KEYWORD INDEX	63
	DOCUMENT LAST PAGE	70

List of Illustrations

Figure 1 METEOR Responder Block Diagram	10
Figure 2 Hardware Module Arrangement	11
Figure 3 Battery Connection Arrangement, No additional Battery Rack fitted	12
Figure 4 Battery Connection Arrangement, Additional Battery Rack fitted	12
Figure 5 Processor PCB Indicators and Switches	14
Figure 6 Backplane PCB switches	15
Figure 7 Telephone Interface Switches and Indicators	17
Figure 8 Typical Installation	23
Figure 9 Backplane PCB Switches	26
Figure 10 Processor PCB Indicators and Switches	27
Figure 11 Telephone Interface Switches and Indicators	29
Figure 12 Battery Connection Arrangement, Additional Battery Rack fitted	33
Figure 13 Battery Connection Arrangement, No additional Battery Rack fitted	33
Figure 14 Processor PCB Monitor LEDs	39
Figure 15 Telephone Interface Monitor LEDs	40
Figure 17 Backplane PCB Switches	44
Figure 18 Backplane PCB Switches	46
Figure 19 Maintenance Terminal Menu Structure	49
Figure 20 Maintenance Terminal Main Menu	50
Figure 21 Maintenance Terminal Summary Menu	50
Figure 22 Call Status Screen	51
Figure 23 PSU Status Screen	53
Figure 24 CPU Status Display	54
Figure 25 Event Log Screen	55
Figure 26 Configuration Screen	57
Figure 27 Modem Tone Screen	58
Figure 28 D type connector viewed from front of Processor PCB	61

1 ABOUT THIS MANUAL

1.1 What is covered

This manual contains all the necessary information required to install, operate and maintain the STC METEOR Responder. Highways Agency Stores Code ERT 0074 1 SPC.

1.2 How to find your way around

The manual is split into several major sections each covering a complete topic. The table of contents at the front of the manual lists topics in the order that they appear, together with their page number. A detailed subject and keyword index is provided at the end allowing quick location of information as required.

If you do not know where to find the information you need on a particular subject use;

- The table of contents if you are interested in a major subject area, or
- The index for specific references to a particular topic (say fuses).

METEOR Product Contact for Telephone Support is: Dave Roe Senior Technical Specialist
01202 782305

1.3 Glossary

BABT	= British Approvals Board for Telecommunications
CPU	= Central Processing Unit
DSP	= Digital Signal Processor/Processing
PCB	= Printed Circuit Board
PCM	= Pulse Code Modulation
PDU	= Power Distribution Unit
PSU	= Power Supply Unit
RCD	= Residual Current Device
STC	= Siemens Traffic Controls
TLC	= Telephone Line Controller

2 EQUIPMENT DESCRIPTION

The METEOR Responder is a routing node used on the NMCS2 motorway emergency telephone system, mounted within an outer case at the side of the motorway. It interfaces up to 24 2-wire* or 12 4-wire emergency telephones to a maximum of 6 instation "telephone line controllers" (TLCs). A degree of fault tolerance is provided by the extensive use of redundant hardware. Back up batteries allow continued operation for up to 48 hours in the event of the loss of AC Mains supply.

*HA use a maximum of 18 2-wire telephones.

2.1 Overview

The basic function of the Responder is to act as an exchange, connecting the Emergency Motorway Telephones to the Control Centre operators.

The METEOR Responder consists of several PCBs and associated Power Supplies, as follows and shown in the Block Diagram overleaf:

- 2 Processor PCBs
- 4 Telephone Interface PCBs (as factory shipped, however it is possible to remove PCBs when less than the maximum number of telephones are connected. See Section 5.3).
- 2 TLC Protection PCBs
- 2 Telephone Line Protection PCBs
- 2 Power Supply Units

A backplane PCB interconnects these PCBs and units.

In addition, a separate unit provides

- Battery support for up to 48 hours of Mains interruption

The Responder takes analogue speech and data signals from the TLC lines and converts these to digital format on the Processor PCBs. The data component is then split from the speech component using digital signal processing techniques. The resulting data component is forwarded to the Processor IC in digital format, while the speech component is forwarded to the Telephone Interface PCBs, also in digital format. The speech is then routed to the appropriate telephone interface, undergoing re-conversion to analogue format before being transmitted to the telephone line.

Speech from the telephone takes the reverse path. It is combined with data destined for the TLCs - again using digital signal processing - and forwarded to the appropriate TLC line.

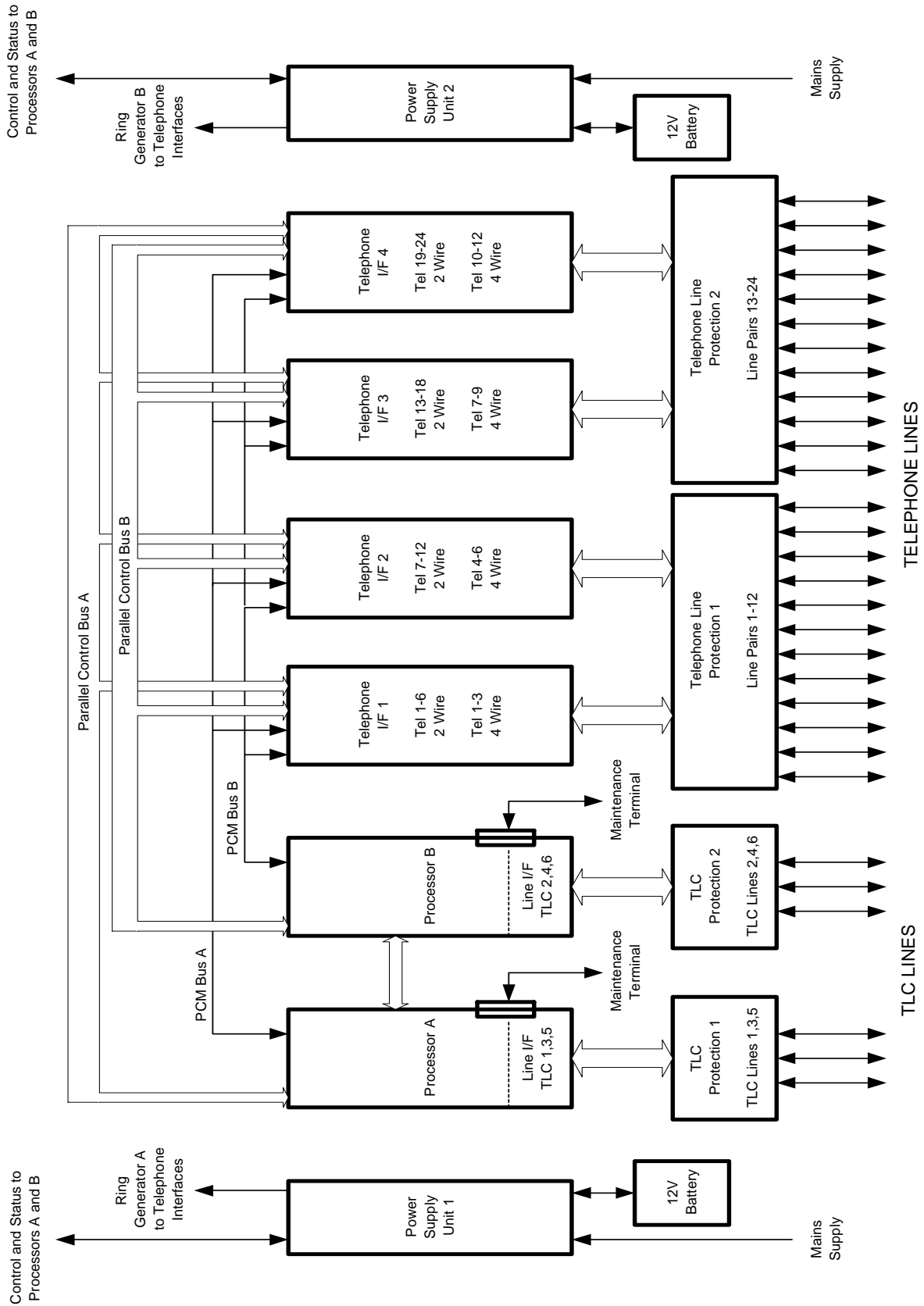

Figure 1 METEOR Responder Block Diagram

2.2 Physical arrangement

The equipment rack is a 19-inch rack, which provides a mounting frame and mechanical protection for all of the Responder hardware. PCBs and other equipment are housed behind protective panels that are removable for installation and maintenance purposes.

Two on board batteries provide power for 16 hours of operation in the event of mains failure.

A separate 19-inch rack is available for housing additional batteries, for use in applications requiring up to 48 hours of battery support.

An overview of the equipment layout is shown below; full dimensions and weights, with and without batteries, is given in Section 7.1:

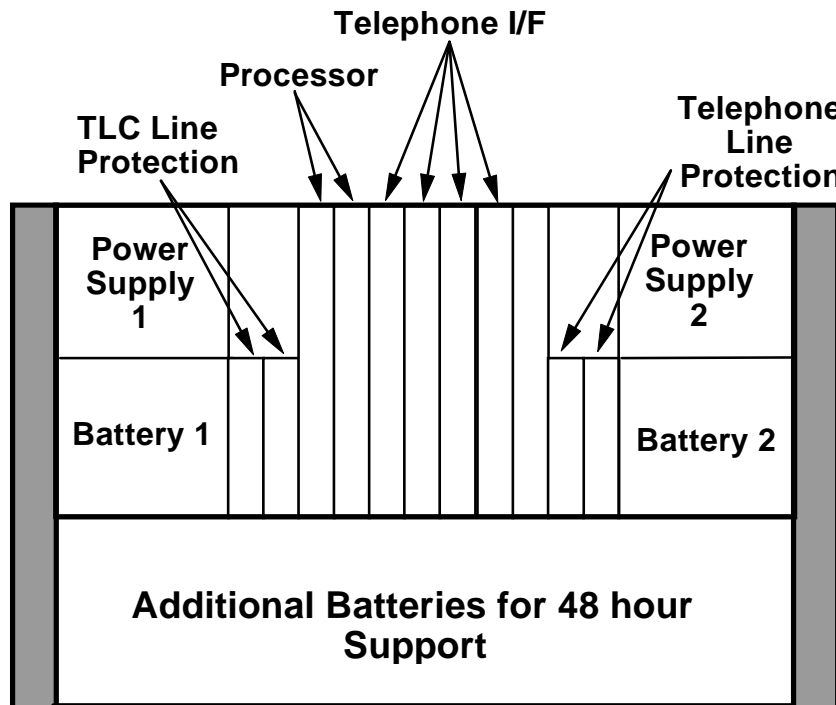

Figure 2 Hardware Module Arrangement

2.3 Power supplies

Two parallel units are provided to allow for a single unit failure without affecting the Responder performance. Under normal circumstances, these units are powered from the Mains supply, although battery backup is provided to cater for up to 15 hours of Mains supply interruption. Up to 48 hours of battery support can be provided by the addition of an extra battery unit. The batteries can be disconnected, and a 12v Accumulator, or similar, can be connected instead. The Power Supply unit has a separate front cover and is actually made up of two separate boards the right hand board is a mains AC/DC converter the left hand board produces all the separate supplies required for the Responder.

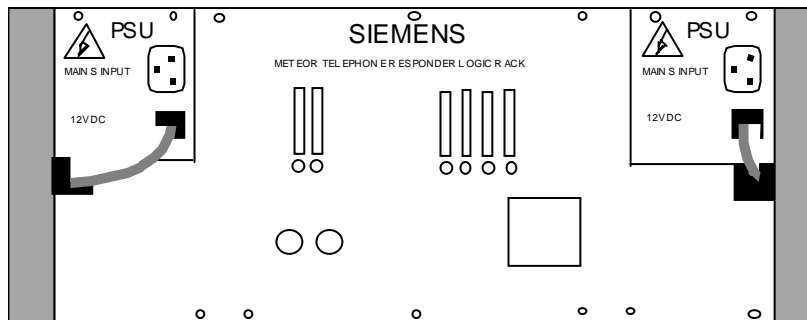

Figure 3 Battery Connection Arrangement, No additional Battery Rack fitted

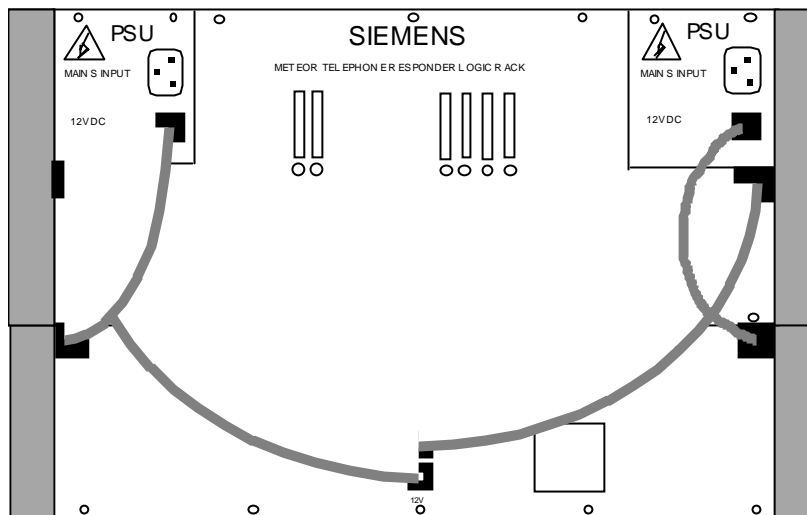

Figure 4 Battery Connection Arrangement, Additional Battery Rack fitted

2.4 PCBs

2.4.1 Processor PCB

The Processor PCB provides all the control and routing functions of the Responder system. In addition, it monitors and logs all fault conditions, and makes these results available via both the TLC interfaces and the Maintenance Port, on request. It also monitors and controls the Ring Generators, and monitors the Power Supply status and Address and Configuration switches mounted on the system backplane. A serial interface allows the two Processor PCBs to communicate with one another, while a second interface supports the Maintenance Port.

Three TLC lines are fed to each Processor PCB (lines 1,3 and 5 to the left hand PCB and 2,4 and 6 to the right), where signals from the TLCs are converted into their separate voice and data constituents through a Digital Signal Processor (DSP) IC. The voice constituents are fed to the Telephone Interface PCBs via the PCM bus, while the data constituents are made available to the host Microprocessor IC. The DSP IC also mixes voice signals from the Telephone Interface PCBs with data from the host, and returns the resulting signals to the TLCs. In addition, the DSP IC provides tones to the Telephone Interface PCBs for use in generating the "ring", "confidence" and "unobtainable" tones to the telephone handsets.

In 4-wire telephone operation no sidetone is generated by the telephone. Therefore, the Responder itself generates a sidetone whose characteristics depend upon the position of link LK2. If pins 2 and 3 are linked then no sidetone is generated. If pins 1 and 2 are linked then a fixed sidetone is generated at $-15\text{dB} \pm 3\text{dB}$ at 1kHz and it remains within $\pm 3\text{dB}$ across the frequency range 300Hz to 3400Hz. If pins 3 and 4 are linked then the fixed sidetone is dynamically suppressed whilst the operator is talking. When the operator's voice signal exceeds -12dB (in the range -12dB to -7dB) the sidetone is suppressed by 20dB. When the operator's voice signal falls below -12dB for 1.1 ± 0.2 seconds, the sidetone is smoothly restored to its original value.

LK2 has no effect during 2-wire telephone operation.

The factory shipped position of LK2 is linking pins 3 and 4 i.e. Dynamic Suppression and the Test Select switch is set to position 0.

Several indicators and associated maintenance facilities are provided which are shown on the diagram on the next page.

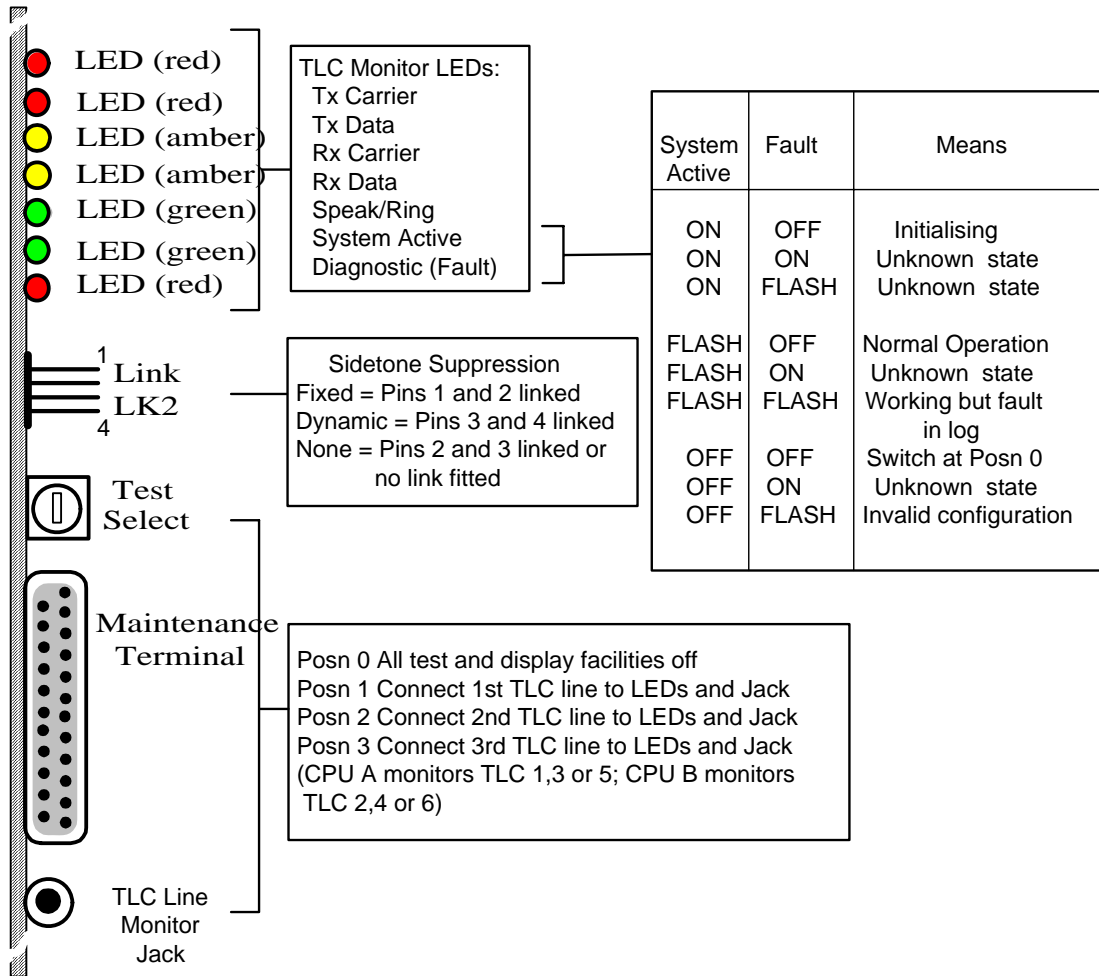
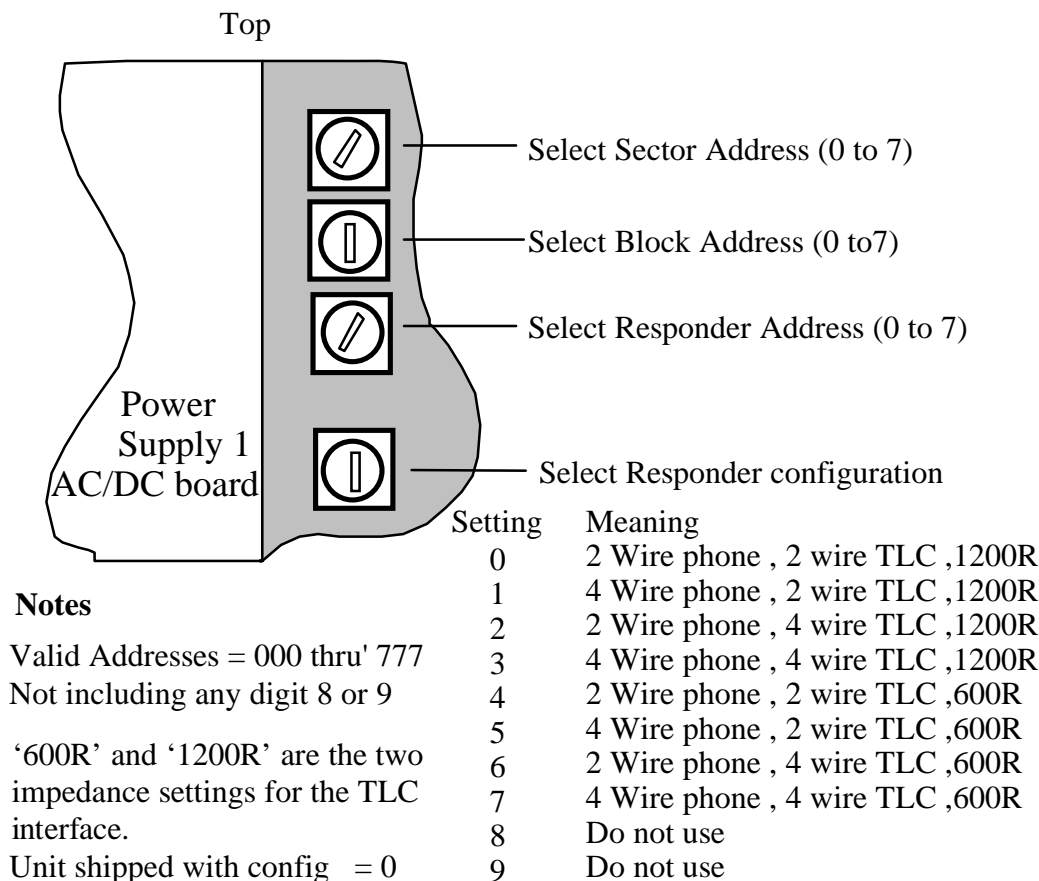

Figure 5 Processor PCB Indicators and Switches

2.4.2 Backplane PCB

The Backplane provides the connection platform for inter-card communications and for bussing power. In addition, the Responder Address and Configuration switches are located on the PCB, facing the front of the unit, behind the Front panel adjacent to the left-hand Power Supply (PSU 1), as shown below.



Notes

Valid Addresses = 000 thru' 777
Not including any digit 8 or 9

'600R' and '1200R' are the two impedance settings for the TLC interface.

Unit shipped with config = 0

Figure 6 Backplane PCB switches

Positions 8 and 9 of the Responder configuration switch are not defined and should not be used. However, if they inadvertently selected no damage to the Responder or equipment connected to it will occur.

The Responder is factory shipped with the address set to 101 and the configuration to mode 0.

Connections to and from all subordinate modules are through connectors on this PCB. In order to prevent insertion of the wrong card into the wrong position, different sized connectors are used in the different card positions.

Separate buses are provided for both the Pulse Code Modulation (PCM) Bus and the standard microprocessor data, address and control signals to connect each Processor PCB to all Telephone Interface PCBs. In this way, a Processor PCB fault will not lock out the other Processor PCB from the Telephone Interface PCBs.

2.4.3 Telephone Interface PCB

The primary purpose of the Telephone Interface PCB is to route voice signals between an internal PCM bus and the individual Telephone lines. It achieves this by use of a time-space Crosspoint Switch and interface circuitry. The Crosspoint switch is controlled from one or other of the Processor PCBs by their general data, address and control buses. Contention between the two Processors is avoided by use of a hardware-generated "busy" signal.

Two types of Telephone Interface PCBs are fitted to the Responder, namely Conferencing and Non-conferencing. One Conferencing and up to three Non-Conferencing PCBs (two in HA systems using 2-wire telephones) are fitted. The Conferencing PCB is fitted to the first position. Under normal operation all calls are routed through the conferencing PCB to allow more than one operator to be connected to any given telephone on the system. However, should the Conferencing PCB fail then calls are routed through individual telephones' associated Interface PCBs but without the ability to achieve conferencing.

Each Telephone Interface PCB interfaces to a maximum of six two-wire connected telephones or three four-wire connected telephones.

The telephones "in service" are selected using a dual in line switch as shown on the diagram on the next page.

Positions greater than 6 on the Test Select switch are not defined and should not be used. However, if they inadvertently selected no damage to the Responder or equipment connected to it will occur.

The units are factory shipped with all the DIL switches in the 'on' position and the Test Select switch to position 0.

Several indicators and associated maintenance facilities are provided which are shown on the diagram on the next page.

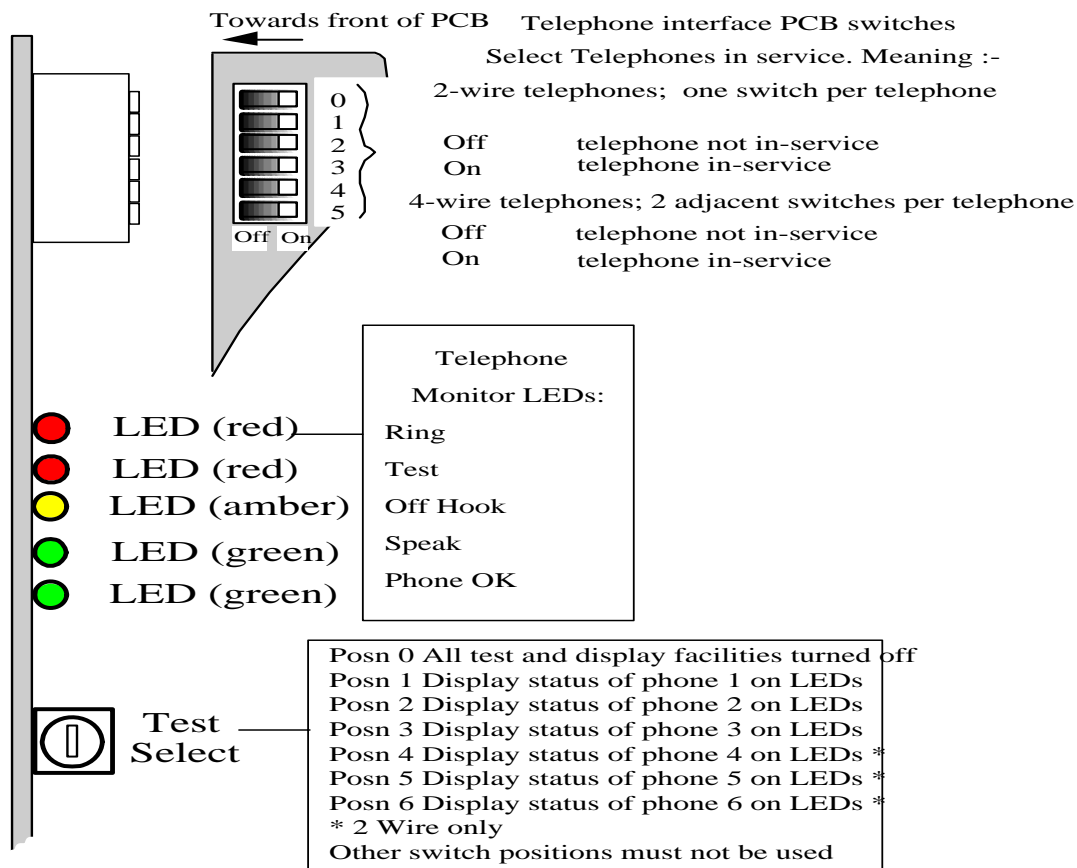

Figure 7 Telephone Interface Switches and Indicators

2.4.4 Line Protection PCBs

The Line Protection PCBs are designed to prevent damage to the Responder circuitry in the event of high-energy transient conditions. This is achieved by use of high voltage absorption devices to route the abnormal condition to Earth.

Two types of Line Protection PCBs are catered for in the METEOR Responder providing TLC Line Protection and Telephone Line Protection.

Each TLC Protection PCB handles a maximum of three TLC interfaces and each Telephone Protection PCB handles a maximum of twelve telephone interfaces. Series fuses are incorporated for each line.

2.5 Equipment operation

2.5.1 Following power-up and reset

The Responder performs a sequence of self-checks following the application of any one of the sources of power, be it mains or battery, or after resetting. The sequence consists of:

- Stack RAM write/read-back check;
- Software PROM checksum check;
- Scratch Pad (data) RAM write/read-back check.

The results of these checks are displayed on the Maintenance Terminal screen as they are performed.

Following these checks, the two Processor PCBs determine which Telephone Interface PCBs are present in the Equipment Rack. While determining which Telephone Interface PCBs are present, they also read the In-Service switches on these PCBs. These switches must be set to the "ON" position (switch levers towards the Backplane) prior to powering-up or resetting for the telephones to be recognised as active. The Processor PCBs then read the Address and Configuration switch settings on the Backplane PCB. All these switches are only ever read following power-up or reset, so any changes to them must be performed with all power (including batteries) removed from the unit, in order for the new settings to be recognised.

The number of electronic addresses for which the Responder is subsequently configured depends upon the slot in which the last recognised Telephone Interface PCB has been placed prior to powering-up or resetting (slots are read from left to right when viewed from the front of the Equipment Rack).

2.5.2 During normal operation

The Responder continuously monitors all telephones for the off-hook condition. Handset rattling is prevented from being presented as a NEW call by the software, which debounces the off-hook condition. If the condition persists for 0.5 seconds, the off-hook detection treats this as a genuine 'lifted handset' and presents a new call to the TLCs after the expiry of a further one second 'off hook' timer.

The Responder also continuously monitors all messages from the TLCs, and responds to any message for which the incoming address matches any of its legitimate electronic addresses.

2.5.3 Telephone testing

A Telephone Test comprises:

- A low voltage test ring waveform applied to the line, to determine whether the Telephone is properly connected,

And

- A brief off-hook simulation to determine whether the Telephone can be detected as off-hook.

The Responder automatically tests all of its telephones at switch-on. Thereafter, the Responder routinely cycles through its telephones, testing each in turn, at nominal 2 minute intervals (3 minute intervals when only 1 telephone interface card/up to 6 telephones are installed). A full telephone test cycle therefore takes:

18 minutes for Responder with up to 6 telephones

24 minutes for Responder with 7-12 telephones

36 minutes for Responder with 13-18 telephones

A telephone can only be tested if it is on hook and has not been off hook in the previous two hours. The results of the test are stored in memory. Both portions of the test must pass in order to generate a "Pass" result. Otherwise, the failure of any portion of the test generates the "Fail" result. If the telephone is in a state that precludes testing, the memory store for that telephone is not changed. When requested by a TLC 'Routine Test' command, the stored test result for each telephone is returned to the TLC.

The stored results of the automatic test on each telephone are also available via the Calls Status Display on the Maintenance Terminal, which gives information for both portions of the test. If a telephone has not yet been tested its result is denoted by asterisks (****), otherwise the "PASS" or "FAIL" text is displayed.

In addition to the automatic test sequence described above it is possible for an operator to initiate a test from his or her console. In this instance the TLC is caused to send a 'Dynamic Test' command, which forces the Responder to carry out a Telephone Test, followed by a 'Results Request' command which forces the Responder to return the results of that test. In this case if the telephone is in a state that precludes testing then an "Unable to Test" result is generated.

3 INSTALLATION

3.1 Safety precautions

In the interests of health and safety, when installing this equipment, the user should be familiar with the information given in the Safety Warning located at the front of this manual.

3.2 Pre-installation checks

Before attempting to install the unit, the following checks must be carried out: -

The Workshop Commissioning checks are performed to ensure that a unit, which has been stored subsequent to delivery from the factory, is still operating to specification. Before shipping the unit to site, the following checks should be carried out: -

- 1) Using a Maintenance Terminal, ensure that the configured address matches the displayed address on any display (See Section 7.4)
- 2) Using a Maintenance Terminal, ensure that the equipment configuration matches the displayed configuration on the Configuration display
- 3) Ensure the equipment operates from a 12V DC source
- 4) Using a Maintenance Terminal, ensure that none of the above actions causes either an ERROR or FATAL Fault/Event Log entry
- 5) Ensure the equipment provides a battery charge current from each Power Supply Unit Note that this may be as low as 90mA for a fully charged battery.
- 6) Ensure that all batteries are removed from the equipment

Before installing the unit, the following checks must be carried out: -

- 1) Ensure that the unit has undergone the Workshop Commissioning checks
- 2) Ensure that Stage 2 & Stage 3 line testing has been performed and certified
- 3) Ensure that all the necessary parts have been included in the installation kit, as follows:-
 - 8 x M6 Captive Nuts
 - 8 x M6 Pan-Head Screws
 - 8 x M6 Plain Washers
 - 2 x Earthing Kit

3.3 Installation of the unit into the cabinet

3.3.1 Preparation of the Responder

Remove the Front Panels from the Responder and Power Supply units.
Connect the Earthing Lead ring tag to the Responder Protective Earth terminal.

3.3.2 Preparation of the Battery Unit

Remove the Front Panel from the Battery Unit.
Install the Earthing Lead ring tag to the Battery Unit.

3.3.3 Installation of the Responder and Battery Unit

Caution

In the interests of health and safety, when installing this equipment, the user should be familiar with the information given in the Safety Warning located at the front of this manual. In particular the equipment must not be installed or removed with the batteries installed. The batteries constitute the majority of the weight of the equipment. Failure to observe this precaution could result in serious injury to personnel and damage to the equipment.

The following operations apply equally to both the Equipment Rack and the Battery Unit.

Although it is easier to install the equipment where access from the rear of the Cabinet is possible, all installation operations can be performed from the front of the Cabinet.

However, where there is restricted access from the rear, it may be preferred to attach the telephone and TLC cables to the Responder backplane prior to installing the equipment rack into the mounting frame. Refer to Section 3.3.7.

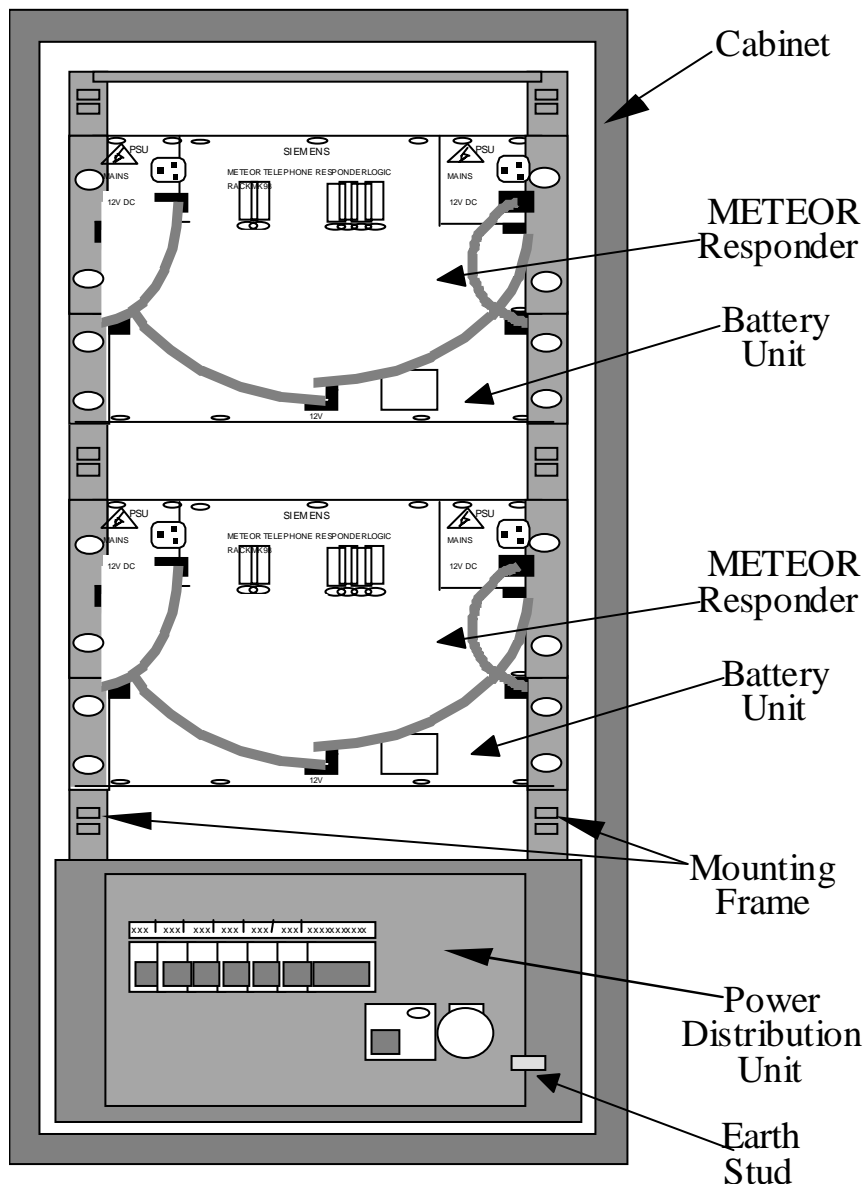

Figure 8 Typical Installation

Fit the four captive nuts in the required positions in the front vertical rails of the 19" frame.

Mount the Equipment Rack onto the front vertical rails of the 19" Frame using the four M6 Pan-Head screws and four M6 External Shake proof washers. Finger-tighten the screws to retain the chassis in the frame. Support the Equipment Rack in the middle underneath with one hand while the top two M6 screws and washers are fitted. This will then provide support to the chassis while the two lower screws are fitted.

With the Equipment Rack securely in place, the four M6 screws at the front of the 19" Frame should be tightened.

3.3.4 Installation of batteries

WARNING

Do not attempt to install batteries into the equipment until the equipment is securely fastened into the sub-frame.

Each battery should be placed partially in the rack and the connections made to the battery cable.

In the case of the batteries located in the main rack, the inline fuse holder should be placed behind the battery (backplane end) and the cable laid along the top of the battery.

The battery should then be slid completely into the rack.

This procedure should then be repeated for the other batteries.

The Battery Unit Front Panel should then be replaced and screwed into position.

As the front panel for the batteries located in the main rack forms part of the front panel for the whole unit, ensure that this cover is replaced when other configuration is complete.

Record on the front panel the date of installation and replacement of the batteries using the marking pen (see tool list Section 7.5). E.g. :-

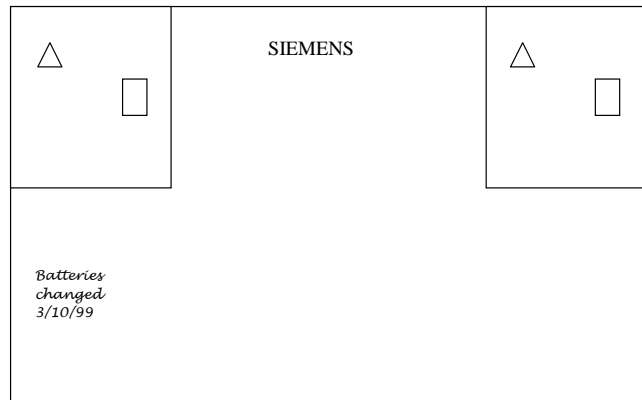

3.3.5 Configuration of switches

The Responder uses a number of switches, located on the various PCBs, to control its configuration. Access to all switches is best achieved with the front panel removed from the unit.

IMPORTANT

Set all switches to the appropriate setting for the site configuration.

The status of all switches is only checked after power up, so any changes must be made with **all** power (battery and Mains) removed from the unit.

In addition, the Responder addressing capabilities (maximum number of electronic addresses) is determined by the positioning of the Telephone Interface PCBs. Again, this is determined following power up. When the unit is powered on following any changes, the new configuration will then be applied.

3.3.5.1 Configuration and Address Switches

The Responder Configuration and Address Switches are located on the backplane PCB, facing the front of the unit, behind the Front panel adjacent to the left-hand Power Supply (PSU 1). Access to these switches is best achieved if the left hand power unit boards are removed as well as the front panel. However, it is possible to adjust the switches with a long-shafted screwdriver without removing the PSU boards if preferred. These switches control the operating mode and electronic address of the unit, as shown below.

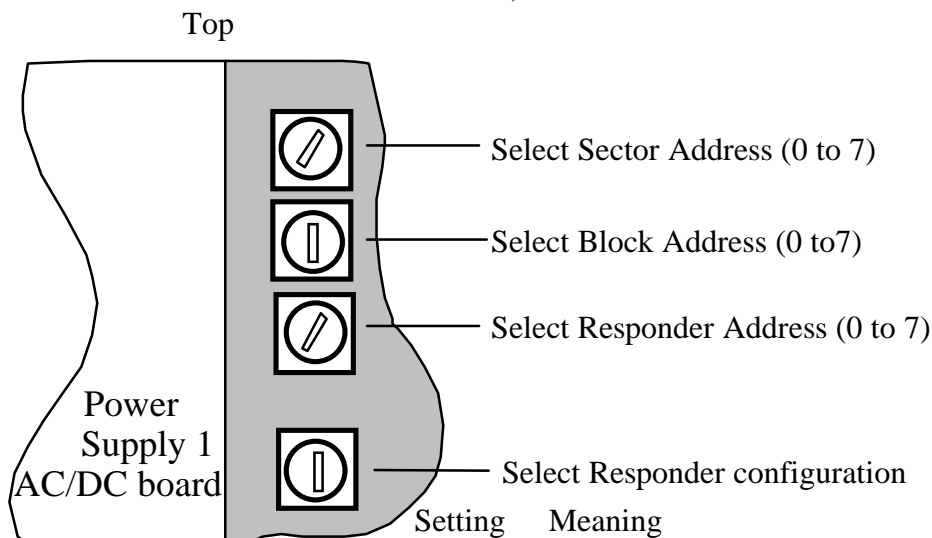

Notes

Valid Addresses = 000 thru' 777

Not including any digit 8 or 9

'600R' and '1200R' are the two impedance settings for the TLC interface.

Unit shipped with config = 0

Figure 9 Backplane PCB Switches

3.3.5.2 The Test Select switch

The Test Select switch on the front edge of each of the Processor PCBs should be set to position 0, to minimise power consumption. Check that these switches are correctly set.

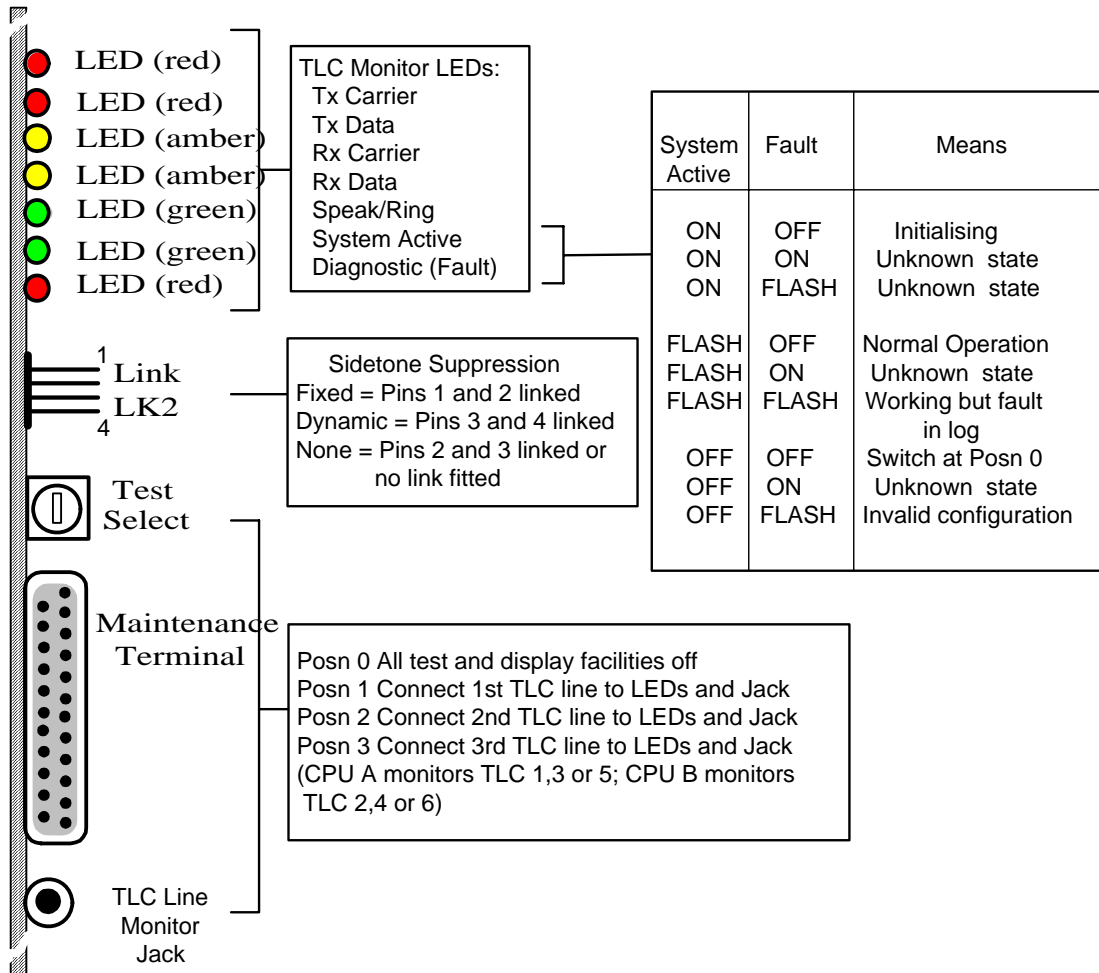

Figure 10 Processor PCB Indicators and Switches

3.3.5.3 Sidetone Link setting

Sidetone is an effect to give the motorist confidence in telephone operation; it allows a proportion of the microphone signal to be fed back to the earpiece of the handset. In a 2-wire telephone sidetone is provided by the telephone itself. In a 4-wire telephone, where the microphone and earpiece circuits are separate, the Responder must provide sidetone. When configured for 4-wire telephone interface, the STC METEOR Responder provides three levels of sidetone - none, fixed and dynamic. When configured for 2-wire telephone interface the settings on this link is ignored, and the Responder does not contribute to the sidetone provided by the telephone.

The link is present on both processor cards. The link setting will apply to all calls connected through that processor card: for instance calls connected through TLC links 1, 3 and 5 will be given sidetone levels appropriate to the link setting on processor A.

The three options are selected by linking pairs of 'LINK 2' pins on the board.(Pin 1 is the top pin).

Link 2 Pins	Sidetone Generation Required
1-2	Fixed Sidetone To Be Generated
2-3	No Sidetone To Be Generated (default for 2-wire operation)
3-4	Dynamic Sidetone To Be Generated
None	No Sidetone To Be Generated

The factory shipped setting for this link is 3-4

3.3.5.4 Monitor Link

This link, located next to the Jack socket, is used to change the level of the signal on the monitoring Jack depending on the impedance of the TLC connection.

For a 1200 Ohm link to the TLC the link must be absent.

For a 600 Ohm link to the TLC the link must be present.

3.3.5.5 Telephone In-Service Switches

The Telephone In-Service Switches are located on the top front edge of each Telephone Interface PCB. All these switches must be facing the rear of the cabinet (the "on" position, as shown below) for the telephones to be correctly recognised. Again the Test Select switch on the front edge of each of the PCBs should be set to position 0, to minimise power consumption. Check that these switches are correctly set.

The factory shipped setting for these switches is all ON

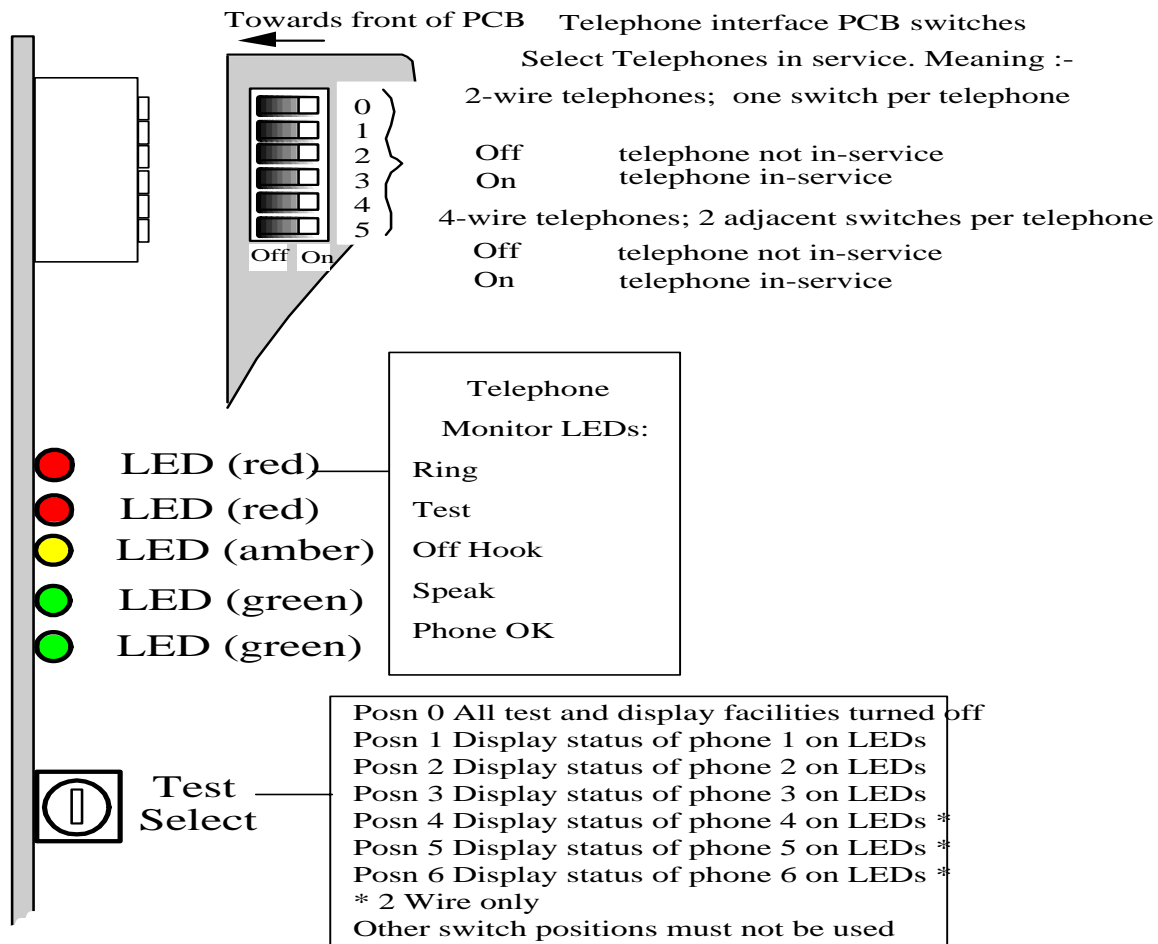

Figure 11 Telephone Interface Switches and Indicators

If only one Telephone Interface PCB is present, but it is located in the third Telephone Interface slot from the left, the Responder interprets this as 3 electronic addresses (and assumes the preceding two PCBs are either missing or faulty). Telephone Interface PCBs should always be placed in consecutive slots nearest the Processor PCBs.

IMPORTANT

The backplane slot third from the left hand side (i.e. adjacent to the processor PCBs) is keyed to accept only "Conferencing", variant 001, Telephone Interface PCBs. The remaining positions can accept either "Conferencing" or "Non-Conferencing" (variant 002) PCBs.

3.3.6 Installation of Power Supplies

When the configuration switches are correct, replace the Power Supply Boards into the unit. Ensure that the cable between the two boards and the earth lead have been attached in both Power Supplies.

Install the free end of the Earthing Leads for both Equipment Rack and Battery Unit to the nearest Earthing point within the cabinet. Cut the leads to length and tie back the free wire using Tiewraps, as appropriate, to suit the installation.

CAUTION RISK OF ELECTRIC SHOCK

When the Earth Leads have been installed, perform an Earth Continuity test using a PAT Tester (or similar) to ensure that each piece of equipment can safely earth 25A before proceeding further. Failure to do so may result in an unearthed installation, which could result in serious injury.

Install the free ends of the Mains power leads to the appropriate Circuit Breaker Assembly in the Power Distribution Unit (PDU) at the base of the cabinet. Circuit Breaker should be rated at 6A (or if a fuse assembly 5A).

WARNING
Before removing any covers from the Power Distribution Unit (PDU), ensure that the Mains supply to the cabinet is isolated.

NOTE
The Mains supply for each Responder must be from a separate feed circuit. Never connect the Responder to a Circuit Breaker Assembly that also feeds other equipment within the cabinet.

WARNING
Before any battery or mains leads are connected to the Responder the Power Supply unit front panel must be in place as there are live parts exposed on the boards behind.

Attach the moulded ends of the Mains power leads to the IEC sockets on the front of each Power Supply Unit. Ensure that the cable run is free from kinks, twists or sharp bends, and that it will not be subjected to chafing when the cabinet door is closed. Tie the cables to suitable anchor points within the cabinet using Tiewraps, as appropriate.

3.3.7 Installation of cables

The Responder is supplied equipped with the following cables:

- 1 x TLC Cable (P/N 667/1/24721/000)

Used when the wiring connection between the Responder and TLC is 2-wire. A 4-wire variant of the TLC cable is available as P/N 667/1/24721/100, which is required when there is a 4-wire connection between the Responder and the TLC.

- 1 x Telephone Cable (P/N 667/1/24722/000)

Used with both two and 4-wire telephone configurations.

The TLC and Telephone cables may be attached prior to installation of the Equipment Rack, as identified in Section 3.3.3, especially when limited access is available from the rear.

The TLC cable attaches to the right-hand Amp-Champ connector, as viewed from the rear of the cabinet, while the telephone cable attaches to the left-hand connector. Connection is made by pressing the Amp-Champ plug of the cable onto the mating socket mounted on the Backplane. The plug is retained at the top by a captive screw (supplied as an integral part of the cable assembly), and by a hook at the bottom (supplied as an integral part of the Backplane). Ensure that the connector has been retained by the hook, and then tighten the screw.

The Terminal Block ends of the cables mate to the appropriate Terminal Block sockets carrying the TLC or Telephone data cables mounted elsewhere within the cabinet. Locate the appropriate Terminal Blocks, mate the two halves, and securely screw the two together.

3.3.8 Termination of cables

When used in a point-to-point communications strategy, or when the unit being installed is the final Responder on a multi-drop link, the communications line must be terminated at the Responder end.

Two termination options are possible:

- 600 Ohm
- 1200 Ohm

The Installer must be informed (by the Customer) of the impedance of the cable network to which the Responder is being attached.

The choice of option depends on the characteristics of the cable network to which the Responder is connected; note that the termination value used at the Responder end should match that used at the upstream cable termination equipment, e.g. Sector Switch.

Wherever UK Private Leased-Lines are being used, the Responder end must be terminated in 600 Ohms. The circuit should also be terminated in 600 ohms at the distant end of the circuit, if such termination is not already included in the equipment connected to the distant end. Failure to do so is a breach of BAPT approval.

Whenever the cable is being terminated, this should be located at, or near to, the point of connection of the line to the METEOR Responder equipment.

3.3.9 Applying power

Before any battery or mains leads are connected to the Responder the Power Supply Unit front panel must in place as there are live parts exposed on the boards behind.

For Responders equipped with a Battery Unit, connect the Battery Cables from the batteries located directly beneath the Power Supplies in the Equipment Rack, to the adjacent socket on the Battery Unit, as shown below (as shorter cables).

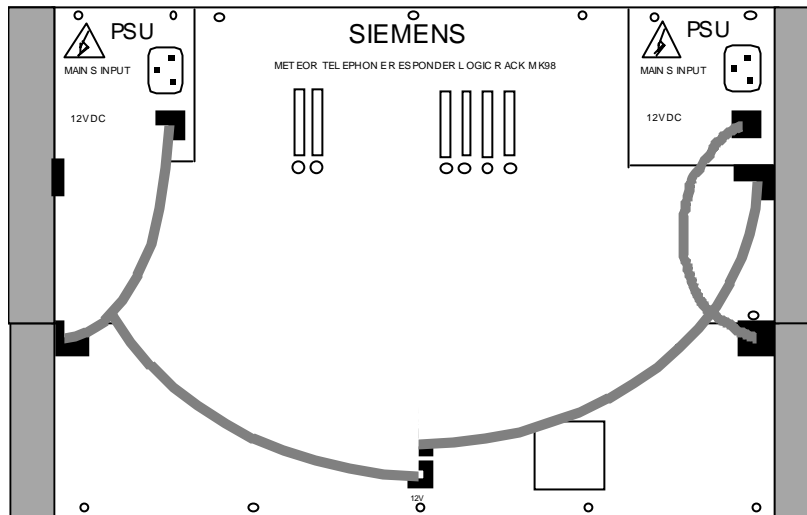

Figure 12 Battery Connection Arrangement, Additional Battery Rack fitted

Power may now be applied to the Responder. The order of powering the unit is not essential, although it is preferred that Mains power is applied before connecting the battery cables to the Power Supplies, to prevent arcing on the battery plug terminals.

Energise the Circuit Breaker in the PDU that controls the Responder.

For Responders equipped with a Battery Unit, connect the Battery Cables from the Battery Unit itself to the sockets on the Power Supplies, as shown above (longer cables).

For Responders operating with no Battery Unit, connect the Battery Cables directly from the batteries located beneath the Power Supplies to the sockets on the Power Supplies themselves, as shown below.

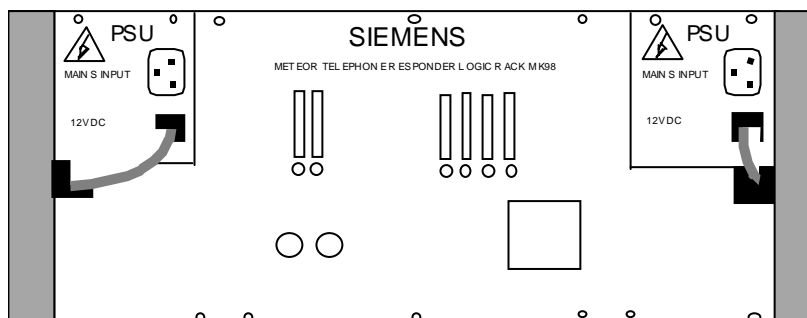

Figure 13 Battery Connection Arrangement, No additional Battery Rack fitted

3.3.10 Commissioning

Basic Power Supply Checks

During the following tests monitor the Power Supply status using the Maintenance Terminal as described in section 6.

Disconnect both battery feeds at their respective PSU connectors and the mains plug from the left hand PSU. Ensure that the Responder remains powered.

Replace the mains plug in the left hand PSU and remove the mains plug from the right hand PSU. Ensure that the Responder remains powered.

Replace the battery connector in the right hand PSU and remove the mains plug from the left hand PSU. Ensure that the Responder remains powered.

Replace the battery connector in the left hand PSU and remove the battery plug from the right hand PSU. Ensure that the Responder remains powered.

Reconnect all power sources.

Telephone Operations

For the following tests, in the Control Office, two OIFs (referred to as OIF1 and OIF2) must be configured as telephone positions.

During the tests monitor the progress / state of the calls using the Monitor LEDs on the Telephone Interface and CPU PCBs (see section 4.3.1). Similarly check the Responder status using the Maintenance Terminal as described in section 6.

a) To show that the Responder can establish speech paths between telephones and the Control Office :-

1. At OIF1 in the Control Office ring out to one of the Telephones connected to the Responder.
2. CHECK that the selected Telephone is ringing.
3. Answer the telephone and CHECK that a speech path is established between the Telephone and OIF1.
4. At another OIF2 select the same Telephone and press SPEAK/RING.
5. CHECK that a second speech path is established from OIF2 to the Telephone.
6. At OIF2 CANCEL the call.
7. At OIF1 CANCEL the call and return the telephone On-Hook.
8. Lift the Telephone Off-Hook.
9. CHECK that:
 - a) a ringing tone is audible at the Telephone.
 - b) the buzzer sounds at OIF1 and OIF2.
10. ACCEPT the call at OIF1.
11. CHECK that at the Telephone the ringing tone ceases and a speech path is established between the Telephone and OIF1.
12. At OIF1 put the call on HOLD.
13. CHECK that a confidence tone is audible at the Telephone.
14. At OIF1 press SPEAK/RING to take the call off HOLD.
15. CHECK that at the Telephone the confidence tone ceases and a speech path is established.
16. At OIF1 cancel the call and replace the Telephone On-Hook.
17. Repeat for the remaining Telephones connected to the Responder.

b) To show that transferred call can be accepted by another TLC:-

1. At OIF1 in the Control Office ring out to one of the Telephones connected to the Responder.
2. Answer the Telephone.
3. At OIF1 transfer to OIF2.
4. CHECK that the speech path between OIF1 and the Telephone is maintained.
5. At OIF2 accept the call.
6. CHECK that there is now a speech path between OIF2 and Telephone but not between OIF1 and the Telephone.
7. At OIF2 cancel the call and replace the Telephone On-Hook.

c) To show that the Responder will recognise and report a Mains supply failure, and continue to operate using a battery back-up :-

1. At OIF1 in the Control Office establish a call to one of the Telephones connected to the Responder.
2. Check that there is a speech path to the Telephone.
3. Disconnect the mains supply at the Responder.
4. Enter telephone maintenance mode at OIF1 and select the option to test the Responder.
5. CHECK that:
 - a) the speech path between OIF1 and the Telephone is maintained during testing.
 - b) a faulty Responder message is displayed on the OCP.
6. Reconnect the power to the Responder.
7. Use the maintenance facility to test the Responder.
8. CHECK that:
 - a) the speech path between OIF1 and the Telephone is maintained.
 - b) the TFLG contains an entry recording the Responder fault and an entry recording the Responder fault clearance.
9. Exit maintenance mode and cancel the call. Replace the Telephone On-Hook.

4 MAINTENANCE

4.1 Safety precautions

In the interests of health and safety, when using or servicing this equipment, the user should be familiar with the information given in the Safety Warning located at the front of this manual.

4.2 Routine maintenance procedure

The only other routine maintenance required by the Responder is a yearly safety check and the periodic replacement of the batteries.

Under normal operating conditions, the batteries should be replaced every four years with new batteries.

All other components and assemblies are designed to be maintenance-free.

4.2.1 Safety Checks

INSULATION TEST

This test is no longer applicable as the unit has 275V protection MOVs on the input.

EARTH LOOP IMPEDANCE TEST

Preparation

The Responder should be switched on and operating normally unless otherwise stated in the following subsections.

SAFETY

During test ensure that NO person is in contact with any part of the cabinet or the Responder.

Tests

Using an LT5 tester:- Connect the Red probe to the live input at the Responder MCB on the PDU and the earth test probe of the tester (Black probe) to the Responder chassis.

(With a 300mA RCD is fitted in the incoming supply to protect the whole cabinet it may be tripped by earth loop impedance tests. If it trips (this is very unusual) it will be necessary to bypass the RCD. To do this, connect the Red probe to live prior to the RCD).

Maximum Allowable Impedance (RCD protected)

The maximum allowable earth loop impedance of an electrical installation following an in-line RCD is calculated by using the formula: -

$$Z = \frac{50 \times 1000}{I(\text{mA})}$$

Where I(mA) is the operating current in milliamps for the RCD.

At the completion of these tests use the Maintenance Terminal, as described in Section 6, to check the operating status of the Responder and its Power Supplies.

4.2.2 Replacement of batteries.

Remove the front panel from the Equipment Rack by unscrewing the slotted captive screws on the panel. Remove the Front Panel from the Battery Unit by unscrewing the slotted captive screws on the panel.

Slide the battery towards the front of the unit, and pull off the faston tags attaching the battery cable to the battery. Withdraw the battery from the unit.

Each replacement battery should be placed partially in the rack and the connections made to the battery cable.

The battery should then be slid completely into the rack.

This procedure should then be repeated for the other replacement batteries.

The Battery Unit Front Panel and the Equipment Rack Front Panels should then be replaced and screwed into position.

Record on the front panel the date of installation and replacement of the batteries using the marking pen (see tool list, Section 7.5). E.g. :-

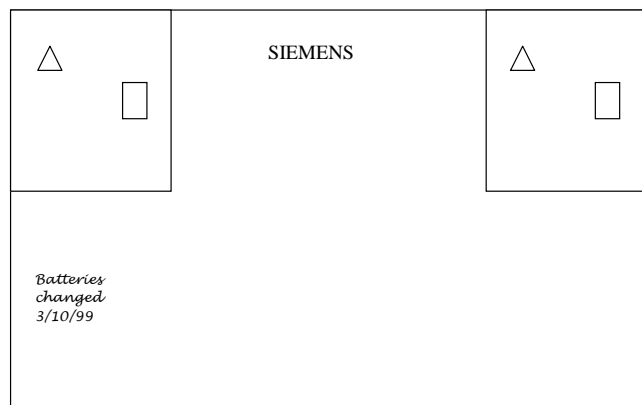

4.3 Fault finding

The Responder is equipped with extensive maintenance facilities for aid in diagnosing faults, and for checking the operation of the Responder. These facilities are available on the Monitor LEDs on the CPU and Telephone Interface PCBs, described in 4.3.2 below, and the Maintenance Terminal, which is detailed in Section 7.4. The Calls Status, PSU Status, CPU Status and Configuration displays of the Maintenance Terminal, when used in conjunction with the extensive Event Log, will enable rapid diagnosis of any faulty module.

However, there are also instances where the fault cannot be isolated by these diagnostics alone. In such instances, further investigation is required. Examples include (but are not limited to):

Symptom	Possible causes
Telephone fails RING test	Telephone disconnected Telephone Protection PCB fault Telephone Interface PCB fault
Telephone fails HOOK test	Telephone Interface PCB fault
Telephone fails RING & HOOK test	Telephone Interface PCB fault
All telephones fail RING test	Telephone cable unplugged Power Supply fault
Telephone presented as OFF-HOOK but is actually on-hook	Telephone line short circuit Telephone Protection PCB fault Telephone Interface PCB fault
No sound heard from "ringing" telephone	Telephone disconnected Power Supply fault Telephone Protection PCB fault Telephone Interface PCB fault
No speech path to telephone (but TLC messages responding)	Telephone disconnected Telephone line short circuit Telephone Protection PCB fault Telephone Interface PCB fault Processor PCB fault
No response on a given TLC line	TLC disconnected TLC line short circuit TLC Protection PCB fault Processor PCB fault
No response to odd numbered or even numbered TLC lines	TLC line multiple faults TLC Protection PCB fault Processor PCB fault
No response to any TLC	Responder not powered up Power Supply multiple faults TLC cable unplugged Incorrect Address/Configuration set
"Phone OK" LED extinguished but Call Status screen shows both Ring and Hook tests as Passed	The phone has been left off hook in Speak mode, Cancel mode or Hold mode for more than 2 hours

4.3.1 Monitor LEDs

The CPU PCB has seven Monitor LEDs and the Interface PCB has five as shown in the following two diagrams. The CPU LEDs are used to monitor the signals and states of the TLC lines and the Interface LEDs the Telephone lines. In both cases rotary switches are used to switch the LEDs to monitor particular lines (see tables in the diagrams). To reduce power drain the selector switches should always be left in the '0' (LEDs disabled) position prior to leaving site.

The top two red LEDs on the CPU PCB illuminate when data is being sent to the TLC. The Tx Carrier LED is a steady indication for the duration of the transmission whilst the Tx Data LED flickers on and off as the data switches between 1s and 0s. The next two amber LEDs have similar functions for data received from the TLC. The top green LED indicates that the selected TLC has a speech path open to a telephone.

The second green LED and the bottom red LED indicate the status of the CPU PCB and this is detailed in the table on the diagram below.

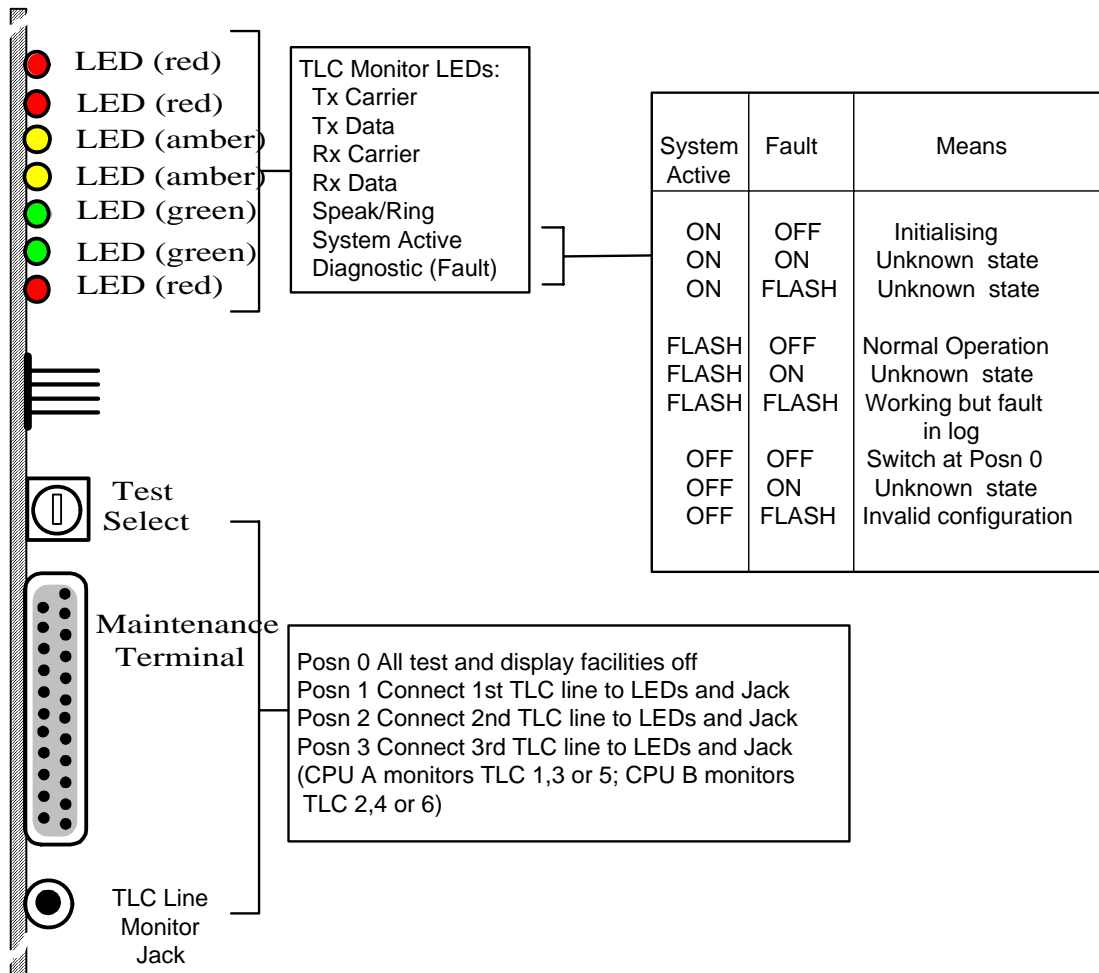

Figure 14 Processor PCB Monitor LEDs

The top red LED on the Interface PCB illuminates when the telephone (selected on the rotary switch) is being rung.

The next red LED illuminates briefly when the telephone is being tested by the Responder.

The amber LED illuminates whenever the telephone is off-hook.

The top green LED indicates that the selected telephone has a speech path open to a TLC.

The bottom green LED illuminates provided that sometime in the previous two hours the telephone has been tested by the Responder and has passed those tests.

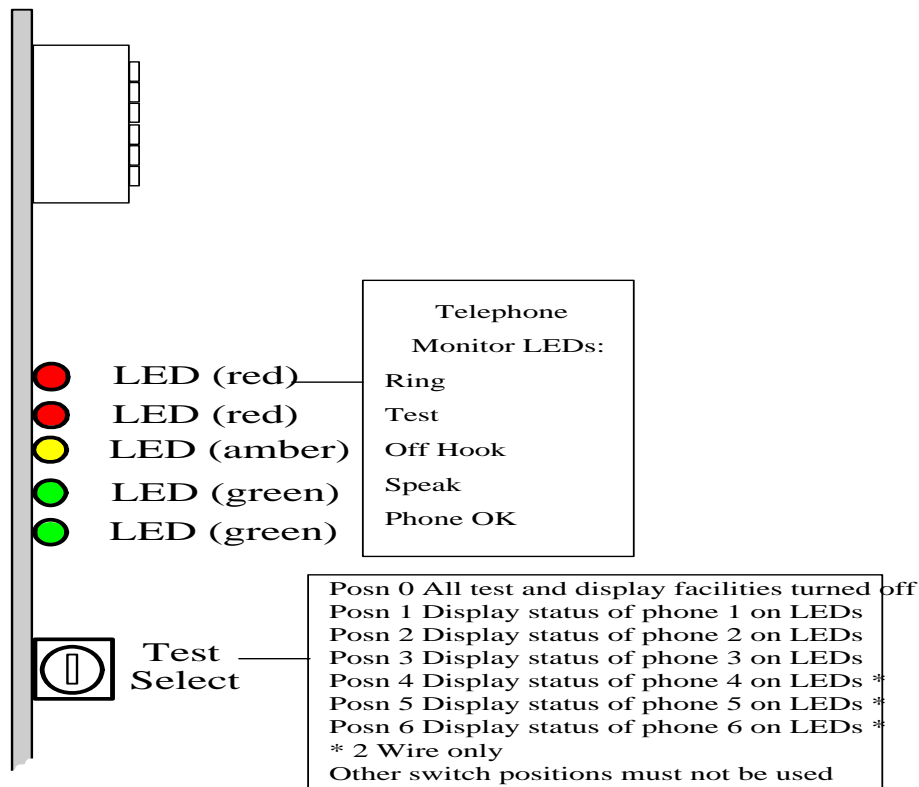

Figure 15 Telephone Interface Monitor LEDs

4.3.2 Monitor Jack

The Test Selector switch on the CPU PCB also routes the selected line signals to the Monitor Jack to allow audio monitoring. These signals should not be used to make accurate line amplitude measurements. If such measurements are required they should be made at the line connection terminal blocks.

The contact arrangement is :-

Body - 0V

Ring - Signals from TLC in 4-wire TLC configuration and all signals in 2-wire.

Tip - Signals to TLC in 4-wire TLC configuration, not used in 2-wire.

4.4 Emergency maintenance procedure

All emergency maintenance is by module replacement. Faulty items are removed from the Equipment Rack and replaced by known good items. The faulty items should then be returned to the Maintenance Depot for fault isolation and repair.

4.4.1 Replacement operations with power removed

To replace a faulty module, perform the following sequence of operations:

- Unplug both battery cable connections from the two Power Supplies.
- Remove Mains power from the unit by switching off the appropriate circuit breaker on the Power Distribution Unit at the bottom of the cabinet.

If replacing any of the Power Supplies;

- Remove the Mains and battery cables from the faulty Power Supply
- Unscrew the slotted screws and remove Power Supply front panel.
- Remove the Power Supply boards from the Equipment Rack.
- Dependant on the fault, replace either one or both of the boards, push the boards home, replace the front panel and tighten all screws.
- Reconnect the Mains cable to the replacement Power Supply.

If replacing any of the PCBs;

- Unscrew the twelve slotted screws and remove the Front Panel from the Equipment Rack.
- Remove the faulty PCB using the ejector tool to release the PCB.
- Insert the replacement PCB and push it fully home.
- Replace the Front Panel and tighten all screws.

To complete the sequence;

- Apply Mains power by switching on the circuit breaker on the PDU.
- Reconnect the battery cables to the Power Supplies.

4.4.2 Replacement operations with power applied

In general, it is recommended that modules should be replaced with all power (both Mains and battery) removed. This will prevent any operational abnormalities from being logged in the Event Log. However, it is possible to replace all PCBs (except the Backplane), and either Power Supply (or one followed by the other) with the unit running.

CAUTION

RISK OF ELECTRIC SHOCK

When replacing Power Supplies with the unit running, ensure that all Mains power is removed from the unit.

To replace any of the Power Supplies with the unit running, perform the following sequence:

- Remove Mains power from the Responder by switching off the appropriate circuit breaker on the Power Distribution Unit at the bottom of the cabinet.
- Remove the Mains and battery cables from the faulty Power Supply
- Unscrew the slotted screws and remove the Power Supply front panel.
- Remove the Power Supply boards from the Equipment Rack.
- Dependant on the fault, replace either one or both of the boards, push the boards home, replace the front panel and tighten all screws.
- Reconnect the Mains and battery cables to the replacement Power Supply.
- Apply Mains power by switching on the circuit breaker on the PDU.

To replace a faulty PCB with the unit running, perform the following sequence of operations:

- Unscrew the twelve slotted screws and remove the Front Panel from the Equipment Rack.
- Remove the faulty PCB using the ejector tool to release the PCB.
- Insert the replacement PCB and push it fully home.
- Replace the Front Panel and tighten all screws.

NOTE

When replacing PCBs with the unit running, unexpected entries may be placed into the Event Log. In addition, it is possible that the unit may reset, which will cause any calls in progress to be cleared down and presented as NEW again to the Control Office.

4.5 Recommended spares

4.5.1 PCBs and other major assemblies

The Responder PCBs contain no field serviceable parts except for fuses. In the event of failure the whole PCB must be replaced with an identical unit. The Siemens part numbers of PCBs and other sub-assemblies are listed below.

Item	Part Number	HA Stores Code
Processor PCB	667/1/30480/001	ERT-0077-2-SPC
Telephone interface (Conferencing) PCB	667/1/30482/001	ERT-0075-2-SPC
Telephone interface (Non-conferencing) PCB	667/1/30482/002	ERT-0076-2-SPC
TLC line protection PCB	667/1/28168/000	ERT-0087-2-SPC
Telephone line protection PCB	667/1/28065/000	ERT-0045-1-SPC
Power Supply (AC - DC)	667/6/25027/000	ERT-0133-2-SPC
Power Supply (DC - DC)	667/1/30484000	ERT-0132-2-SPC
12V (12Ah) battery	418/4/42314/020	Not Stocked

4.5.2 Fuses

Several fuses are provided to protect the equipment in case of malfunction or abnormal operating conditions.

WARNING

Fuses must only be replaced with ones of the correct part number. The use of incorrect fuses may irreparably damage the equipment.

Location	Type	Part Number
Telephone protection PCB	1A slow blow	518/4/97040/035
TLC protection PCB	1A slow blow	518/4/97040/035
PSU (FS1)	5A slow blow	518/4/90284/008
PSU	1A slow blow	518/4/90284/005
Battery Lead in line	10 quick blow	518/4/90286/009
Battery Tray (Front Panel) FS1	5A slow blow	518/4/90284/008

4.5.3 Line Protection Card fuse replacement

The fuses on these cards are not mounted in holders but soldered directly onto the card. Fuse replacement is effected by unsoldering the failed fuse and soldering in a new fuse.

5 RECONFIGURING THE RESPONDER

The Responder may be reconfigured at any time with the unit in situ.

5.1 Changing the connection characteristics

The Responder may be connected in either 2-wire or 4-wire mode to either (or both) the TLCs and the Telephones. To change characteristics, the following sequence should be performed:

- Unplug both battery cable connections from the two Power Supplies.
- Remove Mains power from the unit by switching off the appropriate circuit breaker on the Power Distribution Unit at the bottom of the cabinet.
- Remove the Mains cable from the left-hand Power Supply Unit.
- Unscrew the slotted screws and remove this Power Supply front panel and then the AC/DC board (the right hand board) from the Equipment Rack.
- Unscrew the slotted screws and remove the Front Panel to gain increased access to the switches.
- Rotate the Configuration Switch to the required position, as shown below

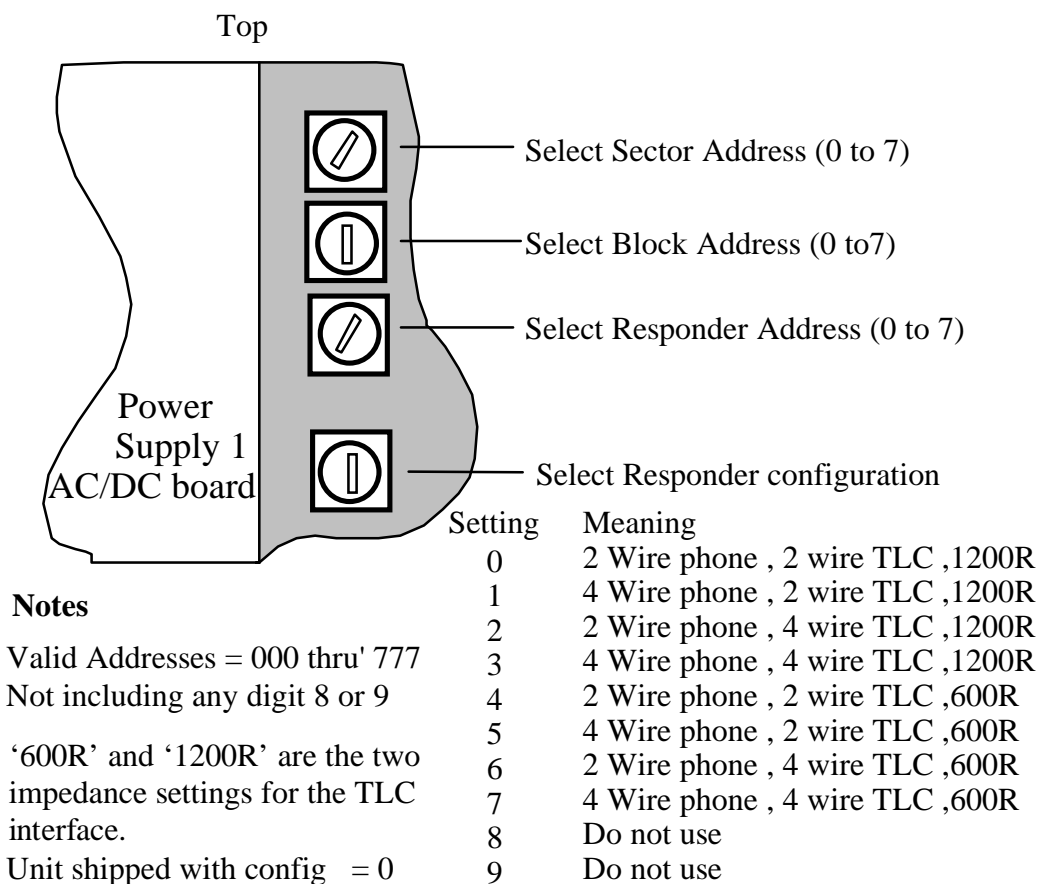

Figure 16 Backplane PCB Switches

- Replace the Front Panel, the Power Supply Unit and its front panel then tighten all screws.

The telephone and TLC cable installation is best performed from the rear of the cabinet, and can be achieved in this manner even when restricted access from the rear is afforded.

TLC Cable (P/N 667/1/24721/000) as factory shipped is used when the wiring connection between the Responder and TLC is 2-wire. A 4-wire variant of the TLC cable is available as P/N 667/1/24721/100 which is required when there is a 4-wire connection between the Responder and the TLC.

Telephone Cable (P/N 667/1/24722/000) as factory shipped is used with both two and 4-wire telephone configurations.

The TLC cable attaches to the right-hand Amp-Champ connector, as viewed from the rear of the cabinet, while the telephone cable attaches to the left-hand connector. Connection is made by pressing the Amp-Champ plug of the cable onto the mating socket mounted on the Backplane. The plug is retained at the top by a captive screw (supplied as an integral part of the cable assembly), and by a hook at the bottom (supplied as an integral part of the Backplane).

- Unscrew the appropriate Terminal Block(s) from their mating halves, and pull the blocks apart.
- Unscrew and remove the cable from the appropriate Amp-Champ connector.
- Insert the replacement TLC Cable into the Amp-Champ connector on the Backplane.
- Ensure the connector is retained by the hook and tighten the captive screw.
- Mate the Terminal Blocks at the other end of the cable with the appropriate mating halves and tighten all screws.

Working from the front of the cabinet:

- Replace the Mains cable into the left-hand Power Supply.
- Apply Mains power by switching on the circuit breaker on the PDU.
- Reconnect the battery cables to the Power Supplies.

5.2 Changing the Responder address

Generally, the Responder does not require its address to be changed when enhancing or reducing the number of telephones catered for (but see section 5.3). However, if necessary, the Base Address (Sector, Block, and Responder) can be changed by changing the Address Switch settings. To change address, the following sequence should be performed:

- Unplug both battery cable connections from the two Power Supplies.
- Remove Mains power from the unit by switching off the appropriate circuit breaker on the Power Distribution Unit at the bottom of the cabinet.
- Remove the Mains cable from the left-hand Power Supply Unit.
- Unscrew the slotted screws and remove this Power Supply front panel and then the AC/DC board (the right hand board) from the Equipment Rack.
- Unscrew the slotted screws and remove the Front Panel to gain increased access to the switches.
- Rotate the Address Switches to the required position, as shown below

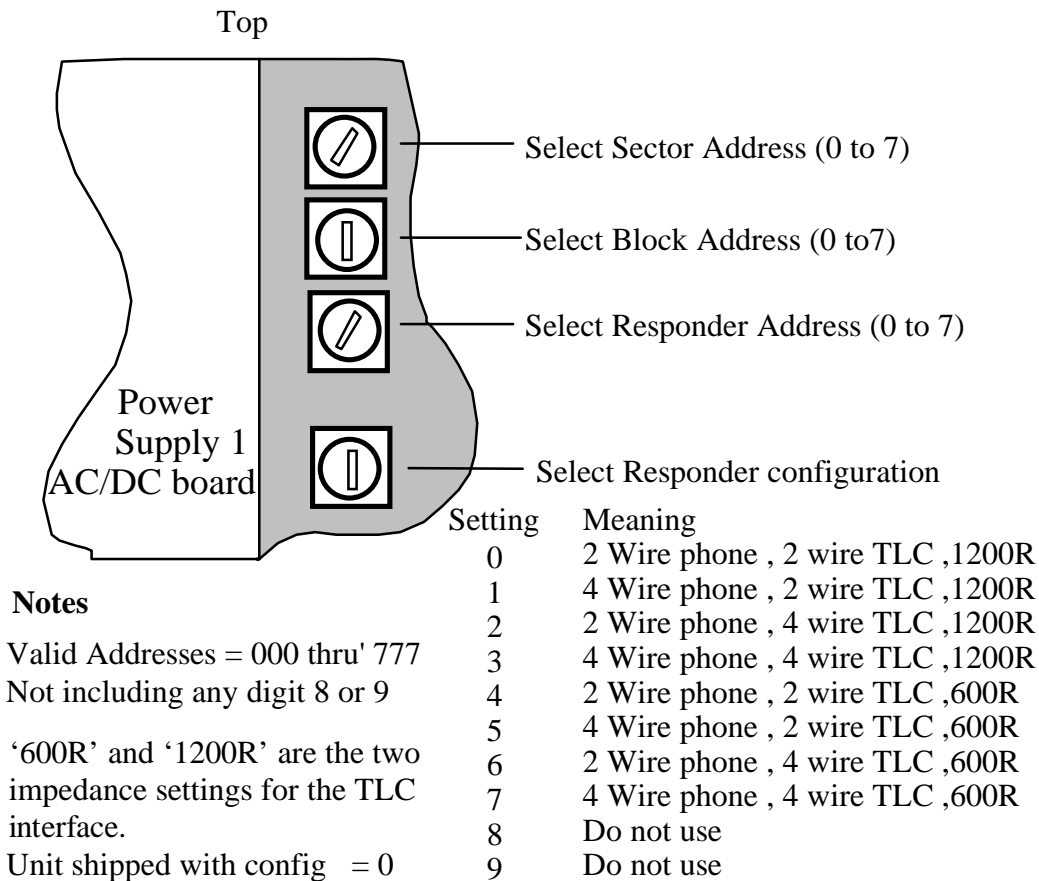

Figure 17 Backplane PCB Switches

- Replace the Front Panel, the Power Supply Unit and its front panel then tighten all screws.
- Replace the Mains cable into the left-hand Power Supply.
- Apply Mains power by switching on the circuit breaker on the PDU.
- Reconnect the battery cables to the Power Supplies.

5.3 Changing the number of telephones catered for

The Responder capabilities can be enhanced or reduced to cater for up to 6, 12, 18* or 24 two-wire telephones, or up to 6 or 12 four-wire telephones, by the simple addition or removal of Telephone Interface PCBs.

* Note HA use a maximum of 18 2-wire telephones

Whilst adding more telephones to a Responder does not require it's addressing to be changed, it must be remembered that additional telephones could utilize an address slot. For instance a Responder with a base address of 123 and configured for 12 2-wire telephones (i.e. 2 interface PCBs) would actually use addresses 123 and 124. If more telephones were added, say another 3, then another interface PCB would need to be fitted and the Responder would then use addresses 123, 124 and 125. This would lead to addressing conflicts if the base address of another Responder in the system had been set to 125. Thus care is needed when expanding a system.

The tables below list the equipment required for various telephone configurations.

2-wire Telephones

Number of Telephones	Telephone I/F PCBs Required	Addresses Required
1 to 6	1	1
7 to 12	2	2
13 to 18	3	3
19 to 24	4	4

4-wire Telephones

Number of Telephones	Telephone I/F PCBs Required	Addresses Required
1 to 3	1	1
4 to 6	2	1
7 to 9	3	2
10 to 12	4	2

If changing from 2-wire to 4-wire (or vice versa), as well as changing the number of telephones catered for, refer first to section 5.1, to change the connection characteristics, then perform the required change in telephones catered for using the appropriate table. If necessary modify the telephones in accordance with the procedure detailed in section 5.4.

When adding PCBs, always locate these in the leftmost vacant slot of the appropriate type for which the card is destined. When removing PCBs, always remove the rightmost PCB of the appropriate type.

IMPORTANT

Do not permanently remove the "Conferencing" variant (/001) Telephone Interface PCB.

The Responder does not require its address to be changed when enhancing or reducing the number of telephones catered for. To change the number of telephones catered for, the following sequence should be performed:

- Unplug both battery cable connections from the two Power Supplies.
- Remove Mains power from the unit by switching off the appropriate circuit breaker on the Power Distribution Unit at the bottom of the cabinet.
- Unscrew the slotted screws and remove the Front Panel from the Equipment Rack.
- Add or remove Telephone Interface PCBs as required.
- Replace the Front Panel and tighten all screws.
- Apply Mains power by switching on the circuit breaker on the PDU.
- Reconnect the battery cables to the Power Supplies.

6 USE OF THE MAINTENANCE TERMINAL

6.1 Maintenance terminal connection

There are two maintenance terminal ports, one for each Processor board. The ports can only be accessed when the Front Panel is removed. They are driven directly by the Responder software via a 25 way 'D' type connector mounted on each board. Data is selected through a series of menus and is displayed in a full screen format. Full details of the terminal and hardware requirements are given in Section 7.4.

6.2 How to use the terminal

The Maintenance Terminal contains nine separate display screens, two of which are menus allowing selection of the various informational displays. The arrangement of these displays is shown below

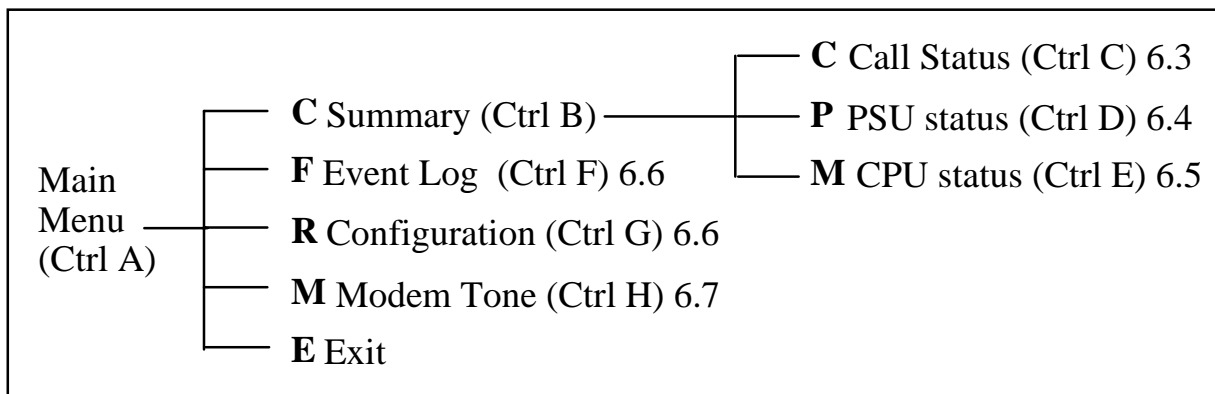

Figure 18 Maintenance Terminal Menu Structure

The maintenance terminal software is invoked whenever a suitable terminal is plugged into the maintenance port of either Processor PCB and the <RETURN> key is pressed after the opening screen appears.

A menu of options is displayed, as shown overleaf, with the required choice being made by entering a designated letter followed by <RETURN>. Alternatively, each display can be directly selected by pressing both the <CONTROL> and appropriate letter keys simultaneously, as defined in the menu structure diagram. Occasionally, when the screen is being refreshed, the key presses are not actioned. Simply re-type the option to have it accepted.

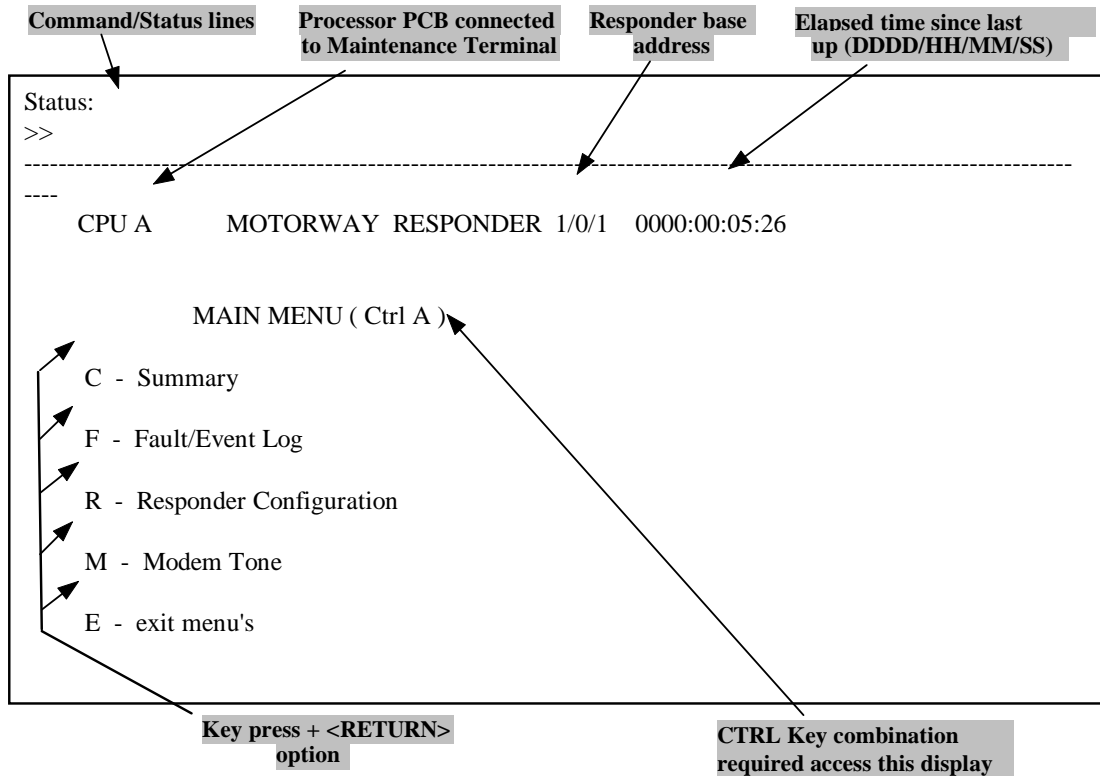

Figure 19 Maintenance Terminal Main Menu

Where sub-options are available (see below) these may be selected once their parent option has been selected.

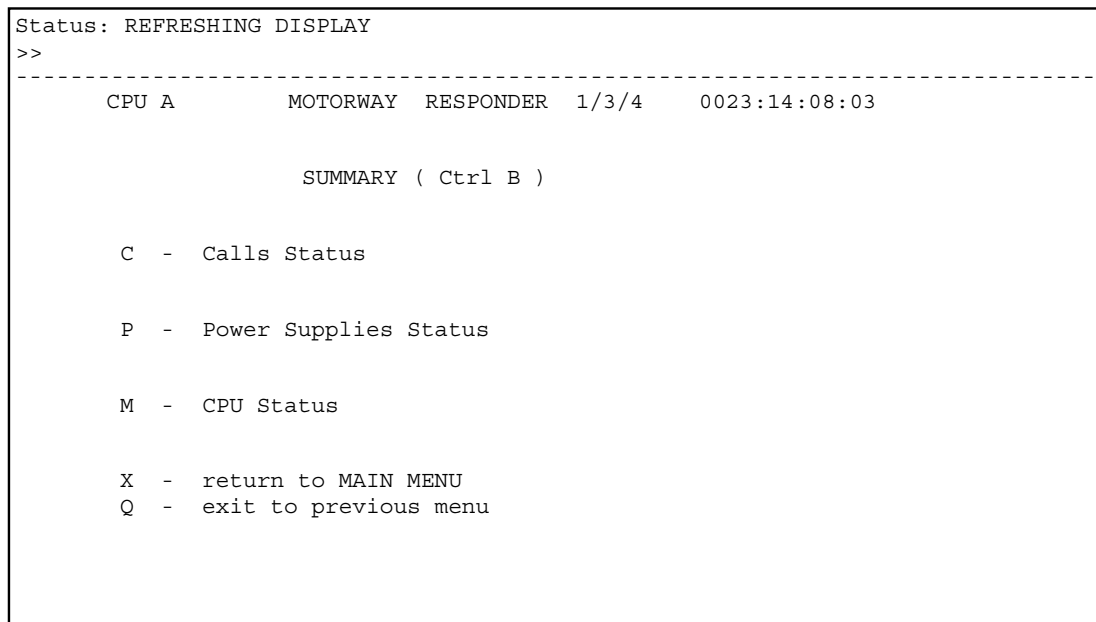

Figure 20 Maintenance Terminal Summary Menu

6.3 Interpreting the Call Status display.

This option provides a means of determining the status of each of the Telephones and Telephone Line Controllers (TLCs). Data for all TLCs is displayed together under several headings: -

Heading	Function
Telephone	Lists the telephone numbers (1 to 6, 7 to 12, etc.)
Hook Status	Indicates which phones are on or off hook
Ring Test	Result of last ring tests carried out on each phone (**** if test could not be carried out)
Hook Test	Result of last hook test carried out on each phone (**** if test could not be carried out)
TLC Status	Status of each phone/TLC. This is updated in response to external changes (e.g. phone being picked up)

The displayed screen is shown below with each main element explained

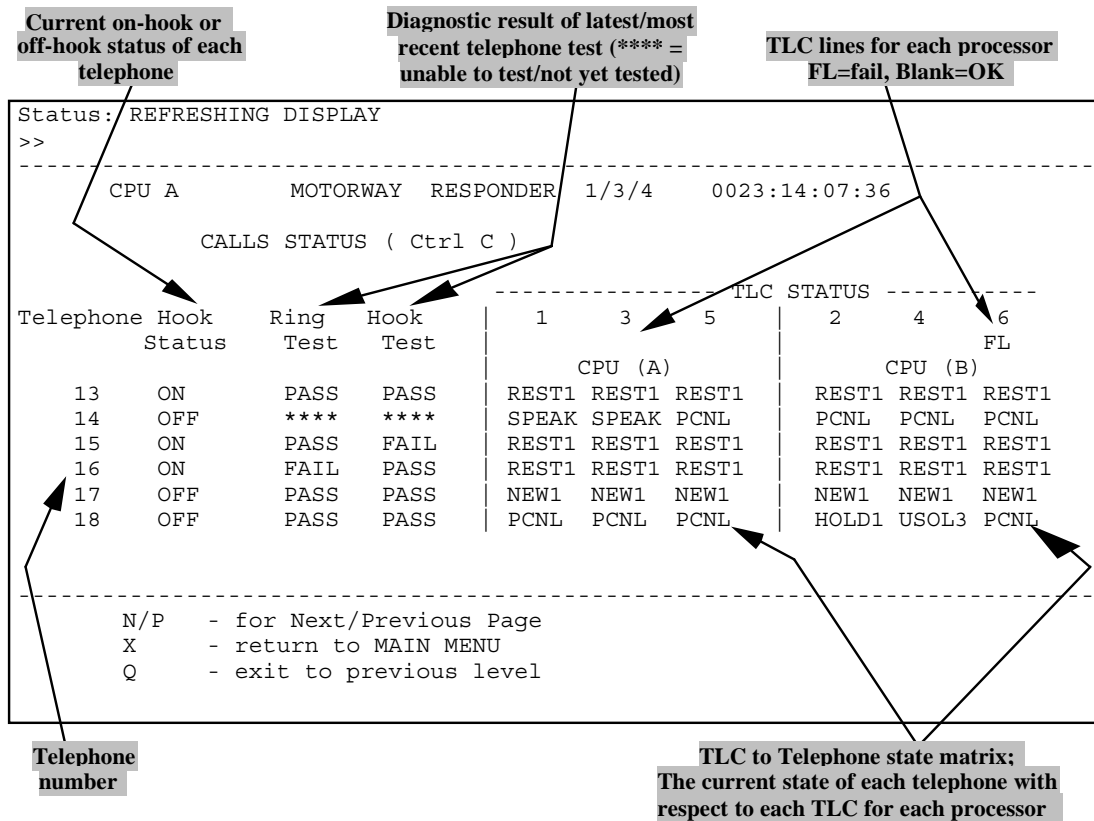

Figure 21 Call Status Screen

If the inter-processor communications have failed, or if the Processor PCB not currently being monitored by the Maintenance Terminal has failed, the appropriate CPU columns are filled with question marks ("?"). These columns are also filled with question marks for the first thirty seconds following power-up or reset.

Note Pressing the 'n' and 'p' keys causes the next and previous pages, respectively, to be displayed.

Possible telephone states displayed in the state matrix are shown below :

Code	State	Full Name	Explanation
REST1	Rest	Rest 1	Phone not used for at least 2 hours
RT1F1	Rest	Rest 1 off hook	Phone goes off hook after being in rest 1
REST2	Rest	Rest 2	Phone used and replaced in last 2 hours
RT2F2	Rest	Rest 2 off hook	Phone goes off hook after being in rest 2
PRST1	Rest	Pseudo-rest 1	Phone put back on hook but operator has not cancelled the call
PR1F5	Rest	Pseudo-rest 1 off hook	Phone goes off hook after being in pseudo-rest 1
PRST2	Active	Pseudo-rest 2	Phone put back on hook but operator has call on hold
PR2F4	Active	Pseudo-rest 2 off hook	Phone goes off hook after being in pseudo-rest 2
RING1	Rest	Ring 1	Phone being rung by this operator
RG1F3	Rest	Ring 1 off hook	Phone goes off hook after being in ring 1
RING2	Rest	Ring 2	Phone being rung by another operator
RG2F9	Rest	Ring 2 off hook	Phone goes off hook after being in ring 2
NEW1	New	New 1	New call originated by taking the phone off hook
N1N5	New	New 1 on hook	Phone goes on hook after being in new 1
NEW2	New	New 2	As New1 but status change as in-station is now aware of call
N2N6	New	New 2 on hook	Phone goes on hook after being in new 2
NEW5	New	New 5	As Unsolicited 3 but status change as in-station is now aware of call
N5N9	New	New 5 on hook	Phone goes on hook after being in new 5
NEW6	New	New 6	As Unsolicited 4 but status change as in-station is now aware of call
N6N11	New	New 6 on hook	Phone goes on hook after being in new 6
USOL3	New	Unsolicited 3	Phone off hook in attempt to re-establish a held call (Pseudo-rest2)
UN3N4	New	Unsolicited 3 on hook	Phone goes on hook after being in unsolicited 3
USOL4	New	Unsolicited 4	Phone off hook in attempt to re-establish an active call (Pseudo-rest1)
UN4N7	New	Unsolicited 4 on hook	Phone goes on hook after being in unsolicited 4
SPEAK	Active	Speak	Phone in speak on specified line/s
SPKN2	Active	Speak on hook	Phone goes on hook after being in speak
HOLD1	Active	Hold 1	Phone on hold and not in speak to any other line, confidence tone generated
HD1N3	Active	Hold 1 on hook	Phone goes on hook after being in hold 1
HOLD2	Active	Hold 2	Phone on hold on one line but in speak on another, confidence tone not generated
HD2N8	Active	Hold 2 on hook	Phone goes on hook after being in hold 2
CNCL1	Active	Cancel 1	Phone cancelled directly from speak i.e. only in speak to one line.
C1N1	Active	Cancel 1 on hook	Phone goes on hook after being in cancel1
PCNL	Active	Pre-cancel	Phone still in speak at another line
PN12	Active	Pre-cancel on hook	Phone goes on hook after being in pre-cancel
CNL2	Active	Cancel 2	Phone cancelled after being in pre-cancel mode
C2N10	Active	Cancel 2 on hook	Phone goes on hook after being in cancel 2 state

6.4 Interpreting the PSU Status display

This option provides a means of determining the status of each of the Power Supply Units (PSUs). Four parameters are displayed for each PSU, as shown.

```

Status: REFRESHING DISPLAY
>>
-----
CPU A          MOTORWAY RESPONDER 1/3/4    0023:14:07:40
                POWER_SUPPLIES_STATUS ( Ctrl D )

                PSU_1      PSU_2
                -----
AC Volts OK      Yes       No
Battery OK       Yes       Yes
DC Volts OK      Yes       No
Ring Generator OK No       Yes

X - return to MAIN MENU
Q - exit to previous menu
    
```

Figure 22 PSU Status Screen

If both PSUs have the AC status marked as "No", then Mains power is absent (or both units have failed AC/DC Converters). If only one is marked as "No", then either its Mains cable has become unplugged, or its AC/DC Converter is faulty.

The battery status is set to "No" when the batteries have become almost fully discharged. However, because the battery monitoring circuit actually tests for a low battery terminal voltage but not an absence of battery voltage (as in the case of a blown fuse or open circuit connection) the battery status indication should be treated with caution. It is still necessary to investigate these types of fault if other symptoms cause the battery output to be suspect.

The DC supply rail status is set to "No" when any one of the three-output supply rails from a particular PSU is faulty. The Responder will continue to operate by using the appropriate supply rail from the other PSU.

The Ring Generator status is set to "No" when the generator test has been unable to detect ring volts from the unit. This test is performed periodically on each PSU. This means that this status should be monitored for at least a minute to ensure that the latest status is being displayed.

6.5 Interpreting the CPU Status display.

This option provides a means of determining the status of each of the Processor PCBs, and also the status of inter-processor communications. Seven parameters are displayed for each processor, as shown.

```

Status: REFRESHING DISPLAY
>>
-----
CPU A      MOTORWAY RESPONDER 1/0/1  0000:00:03:23

      CPU STATUS ( Ctrl E )

                CPU(A)                CPU(B)
                -----
S/W Issue       000.R                   000.R
S/W Part Number 667/TZ/12898/000        667/TZ/12898/000
S/W Built on    02/02/99-15:22:51       02/02/99-15:22:51

S/W Checks      PASS                   PASS

TLC Lines       FAIL                   FAIL

Ring Tests      FAIL                   FAIL

Hook Tests      PASS                   PASS

X - return to MAIN MENU
Q - exit to previous menu
    
```

Figure 23 CPU Status Display

If the inter-processor communications have failed, or if the Processor PCB not currently being monitored by the Maintenance Terminal has failed, the appropriate column is filled with question marks ("?"). This column is also filled with question marks for the first few seconds following power-up or reset.

This screen allows quick determination of whether any tests have failed (i.e. TLC lines, or Telephone Ring or Hook tests). For failures in the last two categories, the Calls Status display should then be interrogated to determine which telephone(s) are marked as "FAIL".

The display can also be used to confirm that the software issue, part number and build date matches for each processor.

6.6 Interpreting the Event Log

All events and faults are entered into the Event Log. The log contains the latest 30 entries and is formatted as shown below, with earliest entries at the top of the log and latest entries at the bottom.

```

Status: REFRESHING DISPLAY
>>
-----
      CPU A          MOTORWAY RESPONDER  1/3/4    0023:14:07:46

      FAULT/EVENT LOG ( Ctrl F )

Entry  Time-stamp  Category Module Func Fault Sub Num ----  Diagnostics  ----
No     DAYS HH MM SS      Id      Id  Id  Id  arg
01     0000 00 00 00 WARNING 0b      0600 0b   05 00 0000 0000 0000 0000 0000
02     NO FAULT EXISTS
03     NO FAULT EXISTS
04     NO FAULT EXISTS
05     NO FAULT EXISTS
06     NO FAULT EXISTS
07     NO FAULT EXISTS
08     NO FAULT EXISTS
09     NO FAULT EXISTS
10     NO FAULT EXISTS

      C      - clear LED error condition
      N/P    - for Next/Previous Page
      X      - return to MAIN MENU
      Q      - exit to previous level
    
```

Figure 24 Event Log Screen

The log will always contain at least one entry, as shown above. This corresponds to normal start-up, when power is first applied to the unit.

When interrogating the log, a note should be made of any event codes, other than the start-up entry, which should then be forwarded to the appropriate service organisation.

Each entry in the log is formatted as shown in the following table

Entry No	Time-stamp DD HH MM SS	Category Id	Module Id	Func Id	Fault Id	Sub Id	Num arg	Diagnostics
2d	4d 2d 2d 2d	7c	2x	4x	2x	2x	2x	20x

The entry format codes (2d 4x, etc.) represent the data type that will be normally held in each field. The number is the number of digits in the field. The letter is the data type: -

- d is a decimal digit
- c is a character and
- x is a hexadecimal digit.

E.g. 4x represents 4 hexadecimal digits such as 0E1F.

Each entry consists of various information fields, the most important of which is explained in the following sections.

Entry No

Entry number is the number of the entry in the Event Log. It is a decimal number. Up to 30 entries are allowed in the log.

Time-stamp

The time-stamp is a measurement of the elapsed time since the last full system power up (this time is not reset on power failure providing battery support is maintained for the duration of the power loss).

Category

Reported events can fall into one of three categories. Different diagnostics' values are displayed depending on the category.

Category	type	Explanation
1	Warning	For info. Has no effect on system operation
2	Error	Error detected. System will continue to function but with possible degradation.
3	Fatal Error	System stopped and restarted automatically

NOTE

All events falling into categories 2 or 3 are reported back to the TLCs.

6.7 Interpreting the Configuration display

The configuration display allows rapid determination of the TLC connection mode (2-wire or 4-wire), the telephone connection mode (again 2- or 4-wire), the number of telephone interfaces recognised at power-up, and the options presented on these telephone interfaces.

The example below shows an eighteen telephone, 2-wire telephone and TLC configured Responder.

```
Status: REFRESHING DISPLAY
>>
-----
CPU A          MOTORWAY RESPONDER  1/3/4    0023:14:07:54

      RESPONDER CONFIGURATION ( Ctrl G )

      2 wire TLC connection 600 ohms

Slot 0 : 2 wire Telephone interface - Conferencing available
Slot 1 : 2 wire Telephone interface - Conferencing not available
Slot 2 : 2 wire Telephone interface - Conferencing not available
Slot 3 : NO CARD PRESENT
Slot 4 : NO CARD PRESENT

      X - return to MAIN MENU
      Q - exit to previous menu
```

Figure 25 Configuration Screen

6.8 Modem Tone Display

For testing purposes the Responder can be forced to generate a tone onto the TLC lines, the tone can be selected for each line independently as shown below. The settings act as toggle switches selected by entering the characters specified below.

Note:

Enabling this function will cause the Responder to transmit a modem tone on the TLC link specified. If the Responder is connected to a live system then the data signals will be corrupted so the system will not function correctly. Disconnecting the engineers terminal from the Responder automatically disables this function.

```

Status: REFRESHING DISPLAY
>>
-----
CPU A      MOTORWAY RESPONDER 1/0/1  0000:00:07:46

MODEM TONE( Ctrl H )

-----

Line 1 Off / On      Mark / Space Tone
Line 2 Off / On      Mark / Space Tone
Line 3 Off / On      Mark / Space Tone

1 - Line 1 On/Off    A - Line 1 Mark/Space Tone
2 - Line 2 On/Off    B - Line 2 Mark/Space Tone
3 - Line 3 On/Off    C - Line 3 Mark/Space Tone
X - return to MAIN MENU
    
```

Figure 26 Modem Tone Screen

6.9 Other test facilities

There are a number of test facilities that are also available by typing in a command as listed below. It should be noted that these functions, whilst of use in the factory, are unlikely to be needed in the field.

Removal of the Terminal will automatically reset FAT1 and FAT2 default settings. FAT3 is a 'one-off' operation that reverts to normal operation at the end of the phone test.

- Fat1 Disable the 15 sec TLC line failure function. (Enables calls to be maintained when routine polling from the TLC is interrupted)
- Fat2 Changes 2 Hour fault timer to 30 Minutes.
- Fat3 Forces the Responder to test all phones.

7 TECHNICAL SPECIFICATION

7.1 Physical characteristics

	Equipment Rack	Battery Unit
Size		
height	266.9 mm (6U)	132.5 mm (3U)
width	482.6 mm (19")	482.6 mm (19")
depth	258.0 mm (Extended)	159.5 mm (Extended)
Weight		
without batteries	11 kg	4 kg
with batteries	19 kg	20 kg

7.2 General electrical characteristics

Power requirements

	Mains input	Auxiliary input
voltage	165 to 264 V ac rms	12v dc \pm 10%
frequency	47 Hz - 52 Hz	dc
rated current	500mA max.	2A max.

Power Supply outputs

Nominal Voltage	Tolerance	Maximum current	Comment
+ 5v dc	\pm 10%	4 A	supplies the logic circuitry
- 5v dc	\pm 10%	1 A	supplies the telephone and line interface circuits
-41v dc	\pm 10%	600 mA	supplies the loop current for the telephone microphones
+12v dc	\pm 10%		charges the batteries
65v ac rms	+15 / - 20%	60 mA	supplies the telephone ring voltage

Power Consumption

Tested on the 8th November 2006 by T. Lelliott at Siemens Poole. Standby consumption - 263mA @230V, Connected to a single telephone - 273mA @230V.

7.3 Communications characteristics

To TLC lines

General characteristics	
maximum number of TLC lines supported	6
Data transmission characteristics	
data rate	50 baud \pm 0.01%
data signalling method	Frequency Shift Keying (FSK)
FSK modulation; logic "0"	2630 Hz \pm 0.1%
FSK modulation; logic "1"	2570 Hz \pm 0.1%
impedance to line (transmitting)	2K ohm min.
signal power	-17 to -19 dBm max. 600 or 1200 ohms
Data reception characteristics	
speech rejection at data frequencies	> 45 dB
Carrier Detect "on" level	- 35 dB
Carrier Detect "off" level	- 38 dB
notch filter lower corner frequency	2300 Hz \pm 100 Hz
notch filter upper corner frequency	2900 Hz \pm 100 Hz
impedance to line (receiving)	30K ohms min.
Speech characteristics	
lower cut-off frequency	300 Hz \pm 100 Hz
data Notch centre frequency	2600 Hz \pm 10 Hz
upper cut-off frequency	3400 Hz \pm 100 Hz
data rejection at speech frequencies	> 45 dB
Passband gain (1 TLC to 1 telephone)	-7 dB \pm 1 dB
Passband gain (6 TLCs to 1 telephone)	-7 dB \pm 1dB
impedance to line (speech)	1K2 ohm min

To telephones

General characteristics	
Maximum number of telephones supported	24 (18 in HA installations)
Minimum number of telephones supported	1
Granularity	1 telephone
Telephone Interface characteristics	
Minimum impedance on-hook	7K ohm
Maximum impedance off-hook	2K ohm
Minimum line length	0 km
Maximum line length	10 km
Telephone bias current	25mA DC to 40mA DC
Telephone bias voltage	-41V DC
Ring voltage	45V to 100V RMS
Ring waveform	Sinusoidal
Test voltage	10V AC rms. \pm 25%
Test waveform	Sinusoidal

7.4 Maintenance terminal

Terminal requirements

General characteristics	
terminal type	DEC VT100 (or later) IBM PC or compatible running terminal emulation software
Terminal emulation for PCs	
approved software	HyperTerminal
Data communication characteristics	
line levels	RS-232
duplex	full
number of start bits	1
number of stop bits	1
number of data bits	8
parity enable	no
parity type	none
transmit speed	9600 baud
receive speed	9600 baud

Terminal connection (characteristics of Processor PCB connection)

General characteristics	
connector style	'D' type
gender	female (socket)
number of ways	25
input protection	100 ohm series resistors

Pin allocation

Pin	Signal	Direction
2	TXD	Input
3	RXD	Output
4	RTS	Input
5	CTS	Output
6	DSR	Output
7	GND	N/A

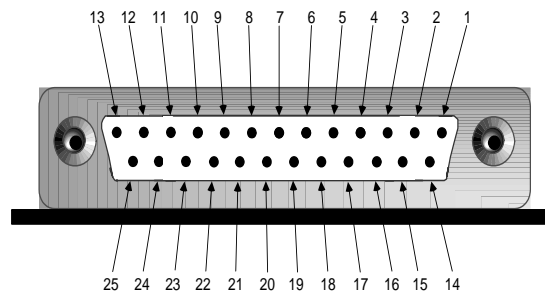

Figure 27 D type connector viewed from front of Processor PCB

7.5 Tool List

The following tools are required to install, commission and maintain the Responder :-

- 'T' Key
- Card extractor (Siemens P/N 667/7/28475/000)
- Terminal screwdriver
- Flat blade screwdriver (large)
- No.4 and No.6 Posidrive screwdrivers
- Maintenance terminal
- Maintenance terminal connection cable (Straight through)
- Crimping Tool
- Wire cutters
- Insulation Tester 16D251B or similar
- Earth Loop Impedance Tester. Megger LT5 or similar
- Black marking pen e.g. RS Components 268-433 or equivalent, suitable for producing markings, which will last at least 4 years.

7.6 Product end of Life Plan

All metalwork can be recycled as scrap Aluminium. The batteries are lead acid and can be separated for recycling and the PCBs can be removed and disposed of as required. There are no precious metals or hazardous waste.

SUBJECT AND KEYWORD INDEX

- Addressing
 - electronic address recognition, 47
- Auxiliary Power Supply, 11, 12
- Batteries, 11, 12, 44
 - connection of, 33
 - installation, 24, 25, 37, 38
- Cables
 - battery connection, 11, 12, 33
 - installation, 31, 48
 - mains connection, 11, 12, 33
 - matching configuration settings, 31, 48
 - telephone, 31, 48
 - termination, 32
 - TLC, 31, 48
- Configuration
 - mode, 45, 48, 58, 59
- Faults
 - diagnosis of, 39, 56, 57
 - Monitor LEDs, 39, 40
- Fuseable resistors, 44
- Fuses, 44
- Handset. (See Maintenance Terminal)
- Installation, 22
 - of Batteries, 24, 25, 37, 38
 - of cables, 31, 48
 - of Power supplies, 30
 - preparation, 21
- Installation of equipment rack, 22
- Installation procedure, 22
- LEDs
 - on processor PCB, 13
- Maintenance
 - emergency procedure, 42
 - replacement of Power Supplies (power applied), 42
 - replacement of Power Supplies (power removed), 42
- Maintenance Terminal
 - Configuration display, 58, 59
 - connection for, 13, 40
 - fault log, 56, 57
 - Fault Log, 39
 - menu structure, 50
 - requirements of, 50
 - telephone test results, 20, 52
 - use of, 50
- PCBs

- Auxiliary, 15
- Backplane, 15
- Processor, 13
 - status of Processors, 55
- Telephone Interface, 15, 16
- Telephone Line Protection, 18
- TLC Line Protection, 18
- Power supplies, 11, 12
 - installation, 30
- Power Supplies
 - status of, 54
- Power-up, 33
- Spares
 - batteries, 44
 - Fuses, 44
 - PCBs, 42, 44, 48
- Specification, 60
- Switches
 - in-service telephones, 16
 - on backplane PCB, 15
 - on processor PCB, 13
 - on telephone interface PCB, 16
 - recognition of settings, 45, 47
 - Responder Address, 15, 47
 - Responder Configuration, 15, 45, 58, 59
- Telephones
 - connection mode, 16
 - monitoring, 19
 - testing, 20
- Termination
 - of cables, 32
- TLC
 - messages, 19