

### TITLE

---

## Long Term Maintenance and Care for S36A

E. C. Wright 02/09/04

This document is to be used in conjunction with Installation, Operation and Maintenance Schedule IOMS 635. Its aim is to provide guidance for owners of equipment which has been in service more than 25 years.

### Contents –

|   |         |
|---|---------|
| Introduction                                | Page 2  |
| Key Questions                               | Page 2  |
| Condition Assessment                        | Page 3  |
| Non-Intrusive PDM                           | Page 3  |
| Dynamic Characteristics                     | Page 5  |
| Asbestos                                    | Page 6  |
| Recommended Care Program                    | Page 6  |
| Spares for Maintenance                      | Page 6  |
| Factory Based Overhaul                      | Page 6  |
| Factory Based Rebuild-Refurbishment         | Page 7  |
| Recommendation for Life Extension           | Page 7  |
| Beta Arc Protection                         | Page 7  |
| Appendix 1 – Recommended Maintenance Regime | Page 9  |
| Appendix 2 – Maintenance Spares             | Page 10 |
| Appendix 3 – Up-rating & Retrofit           | Page 22 |

# SIEMENS Transmission and Distribution

## REYROLLE PRODUCT SERVICES

---

### ***Introduction***

During normal every day operation, switchgear works well within its design envelope and therefore, even after many years of service, appears superficially to be OK.

**Fault clearance however may require the equipment to work at near maximum performance and substandard equipment will be susceptible to significant damage.**

To maintain rating capability key components/functions must be in good operational condition:

**The above does not indicate that the product has a limited lifespan, in fact the S36A range has proven to be very reliable when well looked after.**

We can actually take advantage of the sub-station history of older equipment to design bespoke maintenance, which will not only extend the working life but will reduce the chance of catastrophic damage and can even reduce maintenance costs.

The owner of older equipment (25 years and beyond) should have the information which will allow him to design a maintenance plan to suit his needs. This document will help with that process.

### ***Key Questions***

1. How often is the equipment switched?
2. Is this switching duty at full rated current or well below rated current?
3. How often does the system see a fault?
4. What environmental conditions exist within the sub-station? – Is the switchgear dirty or damp or both? (we are concerned here mainly with the primary insulation)
5. Do we know the condition of the primary functional systems of the switchgear –
  - a. Primary Insulation.
  - b. Contacts, and Arc Chutes.
  - c. The dynamic operating characteristics of mechanism and contacts.

Points 1 to 4 should be available from historical records and we will look later how we will use this information.

Point 5 is actually our recommended starting point. We feel it is logical to make a condition assessment of the equipment, and instigate any repairs prior to introducing a new maintenance regime. Using the condition assessment approach at suitable intervals will also help ensure full rating capability is maintained.

# SIEMENS Transmission and Distribution

## REYROLLE PRODUCT SERVICES

---

### Condition Assessment

#### Recommended site testing For condition assessment of Reyrolle S36A

Speed Curving - In house electronic system

Using original test  
parameters.



Non-intrusive Discharge

### Non-intrusive Discharge Monitoring.

Discharge monitoring is recommended to identify any possible deterioration of filled joints such as the shrouds in the Busbar and Transformer Chambers, surface discharges on primary insulation and similar possible sources.

The system used is non-intrusive. Magnetic probes are attached to the outer skin of the switchgear and are designed to pickup magnetic wave pulses, a phenomenon of electrical discharge. Each probe will pick up a source of discharge but the monitor can determine by time of flight which probe is closest to the source. (see diagrams below) The monitor sweeps the probes approximately every 5 minutes over a period (usually one week) and therefore can determine if the problem is constant, the level and therefore the severity. Recommendations will be given.

Owners of the switchgear can be shown how to transfer monitoring equipment from one board the next and e-mail information to ourselves for analysis.

# SIEMENS Transmission and Distribution

## REYROLLE PRODUCT SERVICES

### Partial Discharge Monitoring

SIEMENS

- Charge transferred from HV busbar to earthed enclosure.
- EM waves emanate away from the discharge site.
- EM waves escape through joint in the enclosure and sweep across the surface of the switchgear.
- EM wave detected by the P.D.M.

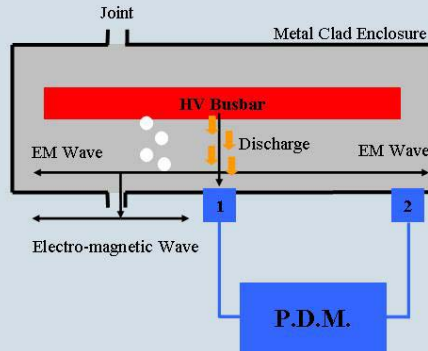

Feb-08

ed.wright@siemens.com T&D/UK/Product Services

11

### Partial Discharge Monitoring

SIEMENS

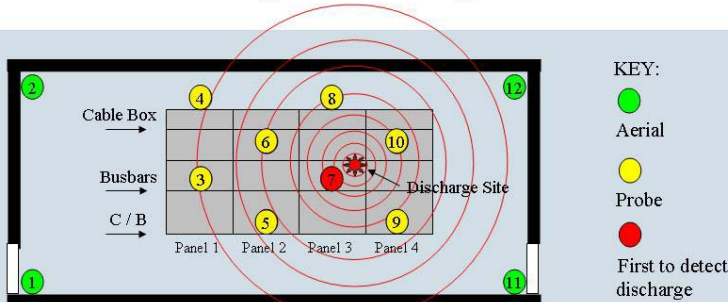

Typical monitoring set-up within a substation (plan view)

- All of the probes detect the discharge from every discharge site on the board.
- The monitor allocates the discharge to the probe at which the discharge arrives first.
- Aerials detect background noise first. Background noise is allocated to aerials.
- The monitor can detect multiple discharge sites within the switchboard.

Feb-08

ed.wright@siemens.com T&D/UK/Product Services



12

Our report gives graphical information, explanation and recommendation for repair. Part of the graphical information from a recent report is shown below.

# SIEMENS Transmission and Distribution

## REYROLLE PRODUCT SERVICES

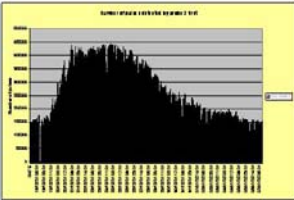
### Partial Discharge Monitoring



This is a graph from one of our recent surveys. The probe is situated on a cable box. This discharge was active constantly at a dangerously high level. As we can see below, the discharge was getting worse as time went on.

The primary insulation involved here would certainly have failed in the near future if left unattended. An unplanned outage would have cost this particular customer around £300,000 a day. This problem would have gone unnoticed if not for the customer requesting a PDM survey. The cable box was successfully repaired in the shortest time possible. Subsequent PDM surveys have given 'discharge free' results.



Feb-08 ed.wright@siemens.com T&D/UK/Product Services 13

## Dynamic Contact and Mechanism Characteristics

When a circuit breaker design passes its short circuit and mechanical operations type tests, certain dynamic characteristics are recorded and used as a profile in all subsequent routine production tests. In other words every production circuit breaker should have the same rating capability. A typical speed curve is shown below.

### Speed Curve



Speed curve analysis allows us to look at the operating characteristics of a circuit breaker in order to determine that it will operate correctly under fault conditions.

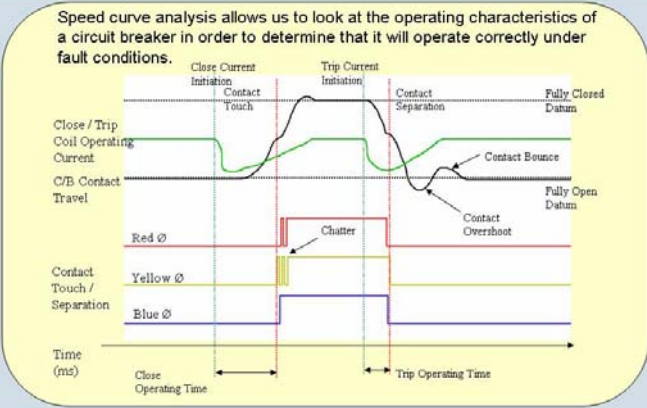

Feb-08 ed.wright@siemens.com T&D/UK/Product Services 7

- The above test combined with visual inspection of Contacts and Arc Chutes will give a very good indication of rating compatibility.

# SIEMENS Transmission and Distribution

## REYROLLE PRODUCT SERVICES

---

### **Asbestos**

It should be noted that S36A Arc Chutes contain White Asbestos components. Current UK legislation requires –

1. Owners should have a register of where asbestos is located.
2. If the Arc Chutes are in good condition they can be left in service.
3. If the Arc Chutes are removed from site they must have the asbestos removed.

VA TECH Product Services can provide an Asbestos removal and Arc Chute refurbishment service.

### ***Recommended Care Program – Appendix 1***

As suggested earlier an alternative program of care to that shown in IOMS 635 should be introduced when the equipment has been in service longer than 25 years.

### ***Spares for normal maintenance needs – Appendix 2***

These spares are recommended for the normal wear and aging of the equipment.

### ***Up-rating & Retrofit – Appendix 3***

### ***Factory based Overhaul***

When site based maintenance procedures cannot achieve consistent and correct circuit breaker operation. Our factory based overhaul service is designed to bring a circuit breaker back to full rating capability with the minimum work. This is achieved by a process of an initial test and inspection to establish work to be done and an agreement with the customer to proceed.

Traveler circuit breakers can be made available to reduce outage times.

### ***Factory based Rebuild-Refurbishment***

This process is recommended for circuit breakers older than 25 years. The process is a complete rebuild with replacement of key components and wiring which achieves an almost “As New” result. The end result not only re-establishes rating but dramatically extends the working life of the equipment.

# SIEMENS Transmission and Distribution

## REYROLLE PRODUCT SERVICES

### **Recommendation to achieve Life Extension and Low Cost of Ownership.**

The process recommended in Appendix 1, a combination of Refurbishment, Condition Assessment and Bespoke Maintenance will extend the working life of the equipment. The logic of this is shown diagrammatically below. The process of targeted or bespoke maintenance also has the potential to reduce maintenance cost.

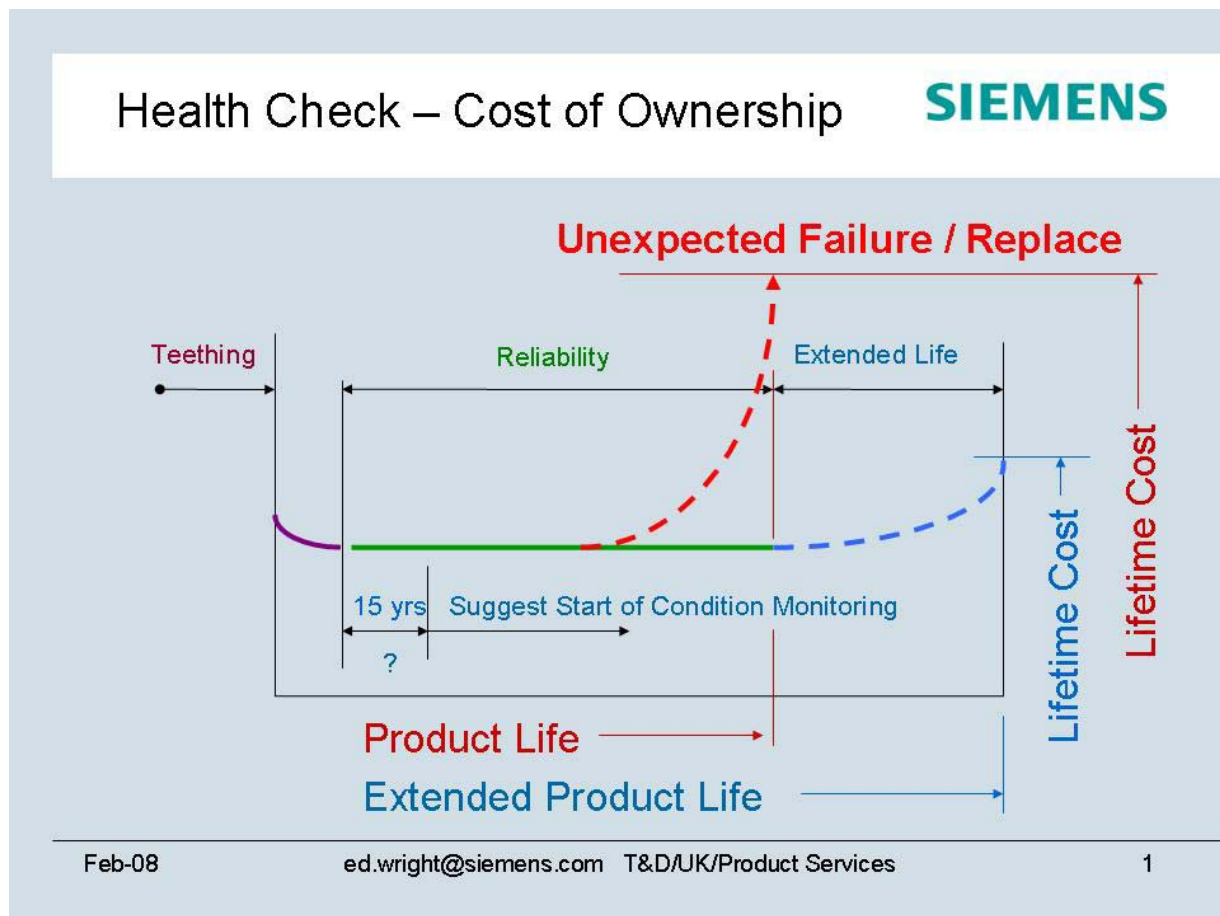

### **BETA ARC FAULT PROTECTION**

In the early 1990's the requirement for Internal Arc Protection on all new Primary Switchgear designs became part of IEC and UK EATS specifications.

The driver for introducing this was of course safety for the operator.

Adding design features to cope with the specification is relatively straight forward when starting a new product design. However retrofitting the capability on existing designs is generally not viable.

# SIEMENS Transmission and Distribution

## REYROLLE PRODUCT SERVICES

The advent of the BETA protection device gives us a viable method of achieving the IEC Arc Fault criteria as a retrofit solution on old air insulated chambers.

As a bonus, BETA not only gives enhanced operator safety, but it dramatically reduces the possibility of collateral damage – Faults will be contained in chamber of origin.

BETA protection can be used to protect the following S36A chambers –

- Circuit Breaker
- Busbar
- Current Transformer
- Air insulated cable boxes. (cable boxes may be compound filled)

The principle of BETA operation is shown below.

## Services Available – BETA arc prot'n SIEMENS

### FEATURES

- Busbar protection primarily for distribution air insulated switchgear
- Arc detected by strong light and tripping supervised by overcurrent elements
- Fast operating time, typically 7ms, minimizes damage caused by a busbar fault
- Simple modular construction scaleable for different busbar arrangements
- Full self supervision for improved reliability
- Easy to install and commission

**Internal Arc Tests**  
Carried out on a three Panel Board of LMT, fitted with BETA, were all cleared within 50ms.  
Because of the short clearance time, damage was minimal.

### Beta - principle of operation

Incoming CB tripped if Arc & Over Current detected Simultaneously

Incoming Supply Increased Current

Arc Sensor picks up light

OC Overcurrent detected

Feb-08ed.wright@siemens.com T&D/UK/Product Services9

# SIEMENS Transmission and Distribution

## REYROLLE PRODUCT SERVICES

---

### APPENDIX 1 – Recommended Maintenance Regime for S36A in service over 25 years.

| Interval   | Circuit Breaker  | Enclosure  |
|--|--|--|
| 25 years   | Rebuild Refurbishment  | Discharge Monitoring   |
| 8 year   | Discharge Monitoring<br>Speed Curve<br>Interrupter Inspection<br>Clean and Lubricate | Discharge Monitoring<br><br>Clean and Lubricate<br>Touch-up paint if necessary |
| 4 year – Only required for poor environments<br><br>(8 year report may suggest additional tests) | Clean and Lubricate<br><br>(Discharge Monitoring)                                    | Clean and Lubricate<br>Touch-up paint if necessary<br>(Discharge Monitoring)   |
| Every 2000 operations at low system current.   | Clean, lubricate and inspect mechanism.  |  |
| Every 2000 operations at high system current.  | Clean, lubricate and inspect mechanism.<br>Interrupter Inspection                    |  |
| After Fault  | Interrupter Inspection   |  |
| Yearly if CB not operated  | Electrical Close & Trip several times.   |  |

### APPENDIX 2 – Maintenance Spares

Extracted from IOMS 635

# SIEMENS Transmission and Distribution

## REYROLLE PRODUCT SERVICES

### RECOMMENDED SPARES

#### 6-6-kV AND 11-kV 500 MVA

Recommended minimum quantities to be kept in site stores or central depot for normal routine maintenance and for maintenance after fault-operation.

Items are common to 6-6-kV and 11-kV panels except where stated.

| Item No. | Description                          | Current Ratings   | Cat. No.                                    | Total No. of panels at the current ratings shown |      |            |
|----------|--------------------------------------|---|---|--|------|------------|
|          |                                      |   |   | 1-6  | 7-20 | 21 or more |
| 1        | Moving arcing-contact                | All ratings and Neutral earthing circuit-breakers   | 771A854                                     | 3  | 6    | 9          |
| 2        | Intermediate moving-contact          | All ratings up to 2400A and Neutral earthing circuit-breakers 3000A                                       | 771A449<br>771A1367                         | 3  | 6    | 9          |
|          |                                      |   |   | 3  | —    | —          |
| 3        | Main moving-contact                  | All ratings up to 2000A and Neutral earthing circuit-breakers 2400A 3000A                                 | 771A507<br>771A685<br>771A1388              | 6  | 12   | 18         |
|          |                                      |   |   | 6  | —    | —          |
|          |                                      |   |   | 6  | —    | —          |
| 4        | Fixed arcing-contact                 | All ratings up to 2400A and Neutral earthing circuit-breakers 3000A                                       | 771A471Y<br>771A1492                        | 3  | 6    | 9          |
|          |                                      |   |   | 3  | —    | —          |
| 5        | Intermediate fixed-contact           | All ratings up to 2400A and Neutral earthing circuit-breakers 3000A                                       | 771A452<br>771A1490                         | 12   | 24   | 36         |
|          |                                      |   |   | 3  | —    | —          |
| 6        | Main fixed-contact unit              | All rating up to 2000A and Neutral earthing circuit-breakers 2400A 3000A                                  | 771A467<br>771A715<br>771A1491              | 3  | 6    | 9          |
|          |                                      |   |   | 3  | —    | —          |
|          |                                      |   |   | 12   | —    | —          |
| 7        | Fixed arc-runner 6-6-kV<br><br>11-kV | All ratings and Neutral earthing circuit-breakers<br><br>All rating and Neutral earthing circuit-breakers | 771A856<br><br>771A1050                     | 3  | 6    | 9          |
|          |                                      |   |   | 3  | 6    | 9          |
| 8        | Insulating contacts                  | All ratings up to 1600A and Neutral earthing circuit-breakers 2000A 2400A 3000A                           | 771A866Y<br>771A1067<br>771A956<br>771A1381 | 6  | 12   | 18         |
|          |                                      |   |   | 6  | —    | —          |
|          |                                      |   |   | 6  | —    | —          |
|          |                                      |   |   | 12   | —    | —          |

# SIEMENS Transmission and Distribution

## REYROLLE PRODUCT SERVICES

### RECOMMENDED SPARES

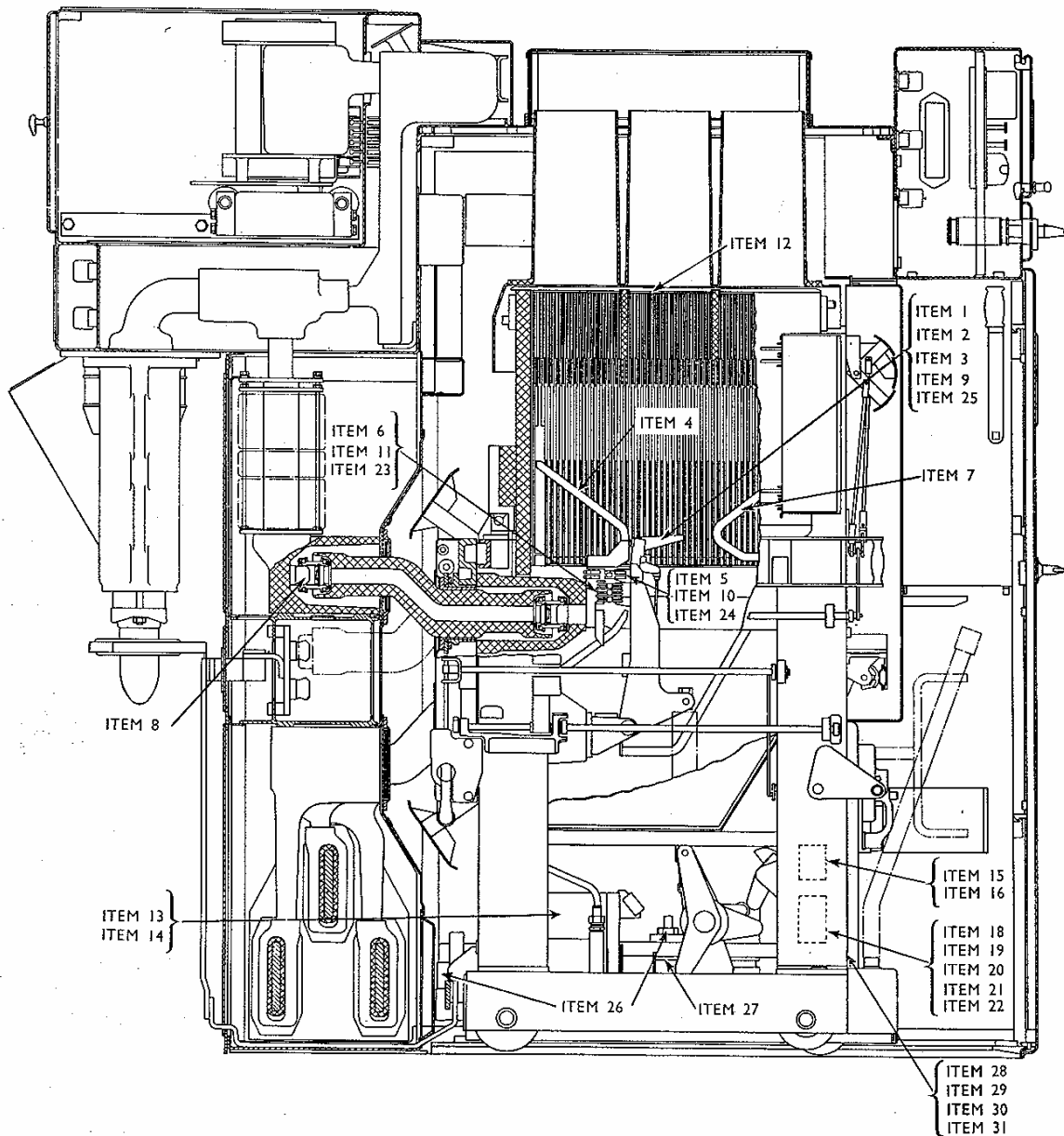

FIG. 40. A TYPICAL 11-kV 800 AMPERES TYPE 1136A 500 MVA PANEL ASSEMBLY.

# SIEMENS Transmission and Distribution

## REYROLLE PRODUCT SERVICES

### RECOMMENDED SPARES

| Item No. | Description                            | Current Ratings  | Cat. No.                       | Total No. of panels at the current ratings shown |      |            |
|----------|--|--|--------------------------------|--|------|------------|
|          |  |  |                                | 1-6  | 7-20 | 21 or more |
| 12       | Arc-chute                              | All rating up to 2400A and Neutral earthing circuit-breakers 3000A         | 771A858Y<br>771A1502           | 3  | 6    | 9          |
|          |  |  |                                | 3  | —    | —          |
| 13       | Closing-coils 100V.                    | All ratings up to 2400A 3000A Neutral earthing circuit-breakers            | 765A741<br>771A1407<br>765A749 | 1  | 2    | 3          |
|          |  |  |                                | 1  | —    | —          |
|          |  |  |                                | 1  | —    | —          |
| 14       | Closing-coils 240V.                    | All ratings up to 2400A 3000A Neutral earthing circuit-breakers            | 765A751<br>775A226<br>765A750  | 1  | 2    | 3          |
|          |  |  |                                | 1  | —    | —          |
|          |  |  |                                | 1  | —    | —          |
| 15       | Trip-coils 110V d.c.                   | All ratings and Neutral earthing circuit-breakers                          | 751A946Y                       | 1  | 2    | 3          |
| 16       | Trip-coils 220/240V d.c.               | All ratings and Neutral earthing circuit-breakers                          | 751A2130                       | 1  | 2    | 3          |
| 18       | Solenoid-contactor contactor           | All ratings and Neutral earthing circuit-breakers                          | 6034A4                         | 4  | 8    | 12         |
| 19       | Solenoid-contactor coils 200/240V d.c. | All ratings and Neutral earthing circuit-breakers                          | 603A21Y                        | 2  | 4    | 6          |
| 20       | Solenoid-contactor coils 110V d.c.     | All ratings and Neutral earthing circuit-breakers                          | 603A28                         | 2  | 4    | 6          |
| 32 to 37 | Fuses                                  | Fuses should be stocked according to type manufacture and rating required. |                                | As required                                      |      |            |
| 38       | Voltage-transformer primary-fuse       | All ratings with a voltage-transformer                                     | 395A8400                       | 3  | 6    | 9          |

It should be noted that all other items on the overall spares list are generally available at short notice from Hebburn Works.

For overseas, the supplying of any of these additional spares should be by arrangement with the customer.

## RECOMMENDED SPARES

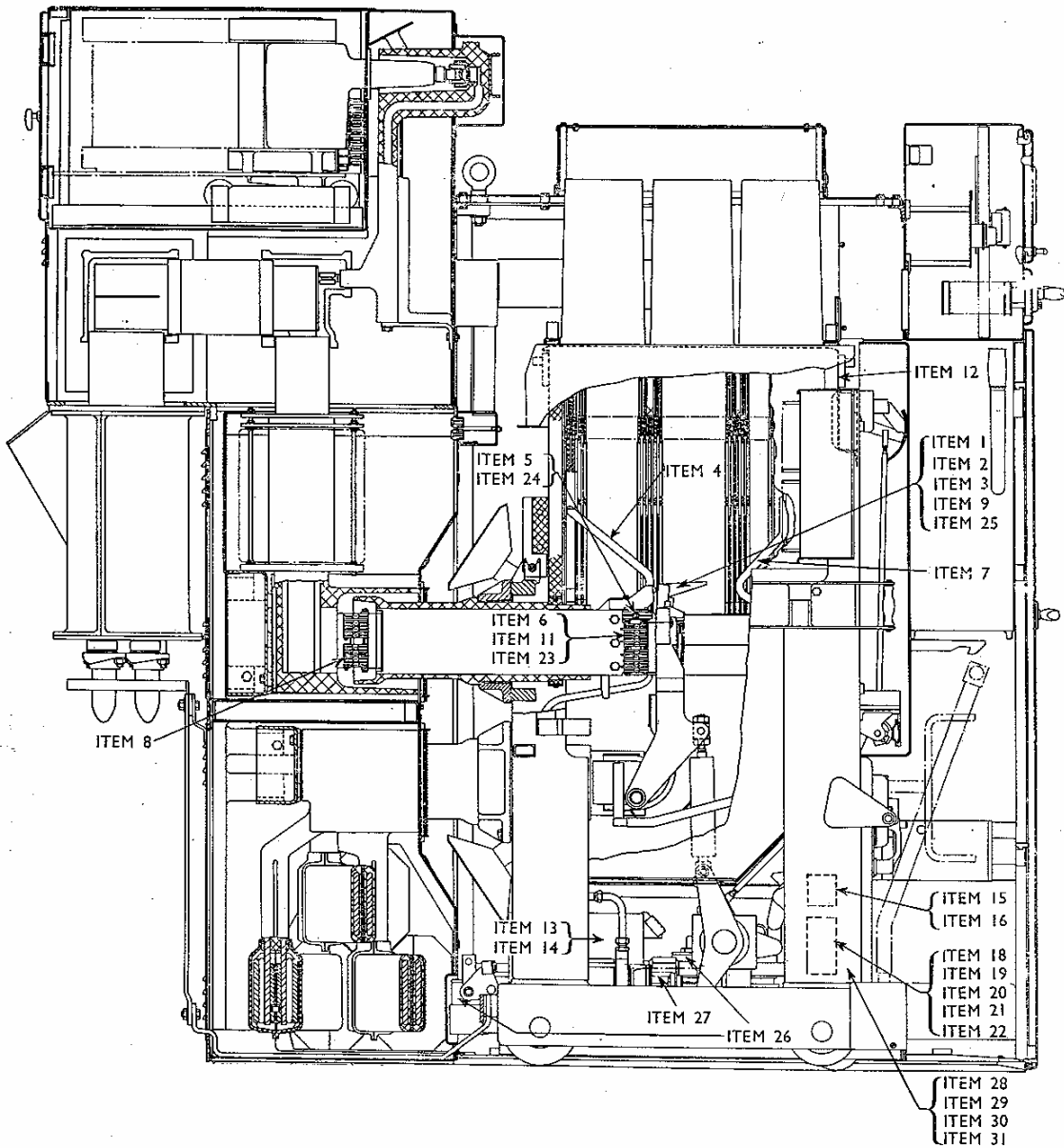

FIG. 41. A TYPICAL 11-kV 3,000 AMPERES TYPE S45A 500 MVA PANEL ASSEMBLY.

# SIEMENS Transmission and Distribution

## REYROLLE PRODUCT SERVICES

### RECOMMENDED SPARES

11-kV 750 MVA

#### CIRCUIT BREAKERS AND NEUTRAL EARTHING CIRCUIT-BREAKERS

Recommended minimum quantities to be kept in site stores or central depot for normal routine maintenance and for maintenance after fault-operation.

| Item No. | Description                 | Current Ratings   | Cat. No.                                    | Total No. of panels at the current ratings shown |      |            |
|----------|-----------------------------|---|---|--|------|------------|
|          |                             |   |   | 1-6  | 7-20 | 21 or more |
| 1        | Moving-arc-ing-contact      | All ratings up to 2400A and Neutral earthing circuit-breakers 3000A             | 771A2169<br>771A2370                        | 3  | 6    | 9          |
|          |                             |   |   | 3  | —    | —          |
| 2        | Intermediate moving-contact | All ratings up to 2400A and Neutral earthing circuit-breakers 3000A             | 771A1901<br>771A2159                        | 3  | 6    | 9          |
|          |                             |   |   | 3  | —    | —          |
| 3        | Main moving-contact         | All ratings up to 2000A and Neutral earthing circuit-breakers 2400A 3000A       | 771A507<br>771A685<br>771A1388              | 6  | 12   | 18         |
|          |                             |   |   | 6  | —    | —          |
|          |                             |   |   | 6  | —    | —          |
| 4        | Fixed arc-ing-contact       | All ratings up to 2400A and Neutral earthing circuit-breakers 3000A             | 771A1913<br>771A1867                        | 3  | 6    | 9          |
|          |                             |   |   | 3  | —    | —          |
| 5        | Fixed-intermediate contact  | All ratings up to 2400A and Neutral earthing circuit-breakers 3000A             | 771A1911<br>771A1490                        | 3  | 6    | 9          |
|          |                             |   |   | 3  | —    | —          |
| 6        | Main fixed-contact unit     | All ratings up to 2000A and Neutral earthing circuit-breakers 2400A 3000A       | 771A467<br>771A715<br>771A1491              | 3  | 6    | 9          |
|          |                             |   |   | 3  | —    | —          |
|          |                             |   |   | 12   | —    | —          |
| 7        | Isolating-contacts          | All ratings up to 1600A and Neutral earthing circuit-breakers 2000A 2400A 3000A | 771A866Y<br>771A1067<br>771A956<br>771A1381 | 6  | 12   | 18         |
|          |                             |   |   | 6  | —    | —          |
|          |                             |   |   | 6  | —    | —          |
|          |                             |   |   | 12   | —    | —          |

# SIEMENS Transmission and Distribution

## REYROLLE PRODUCT SERVICES

### RECOMMENDED SPARES

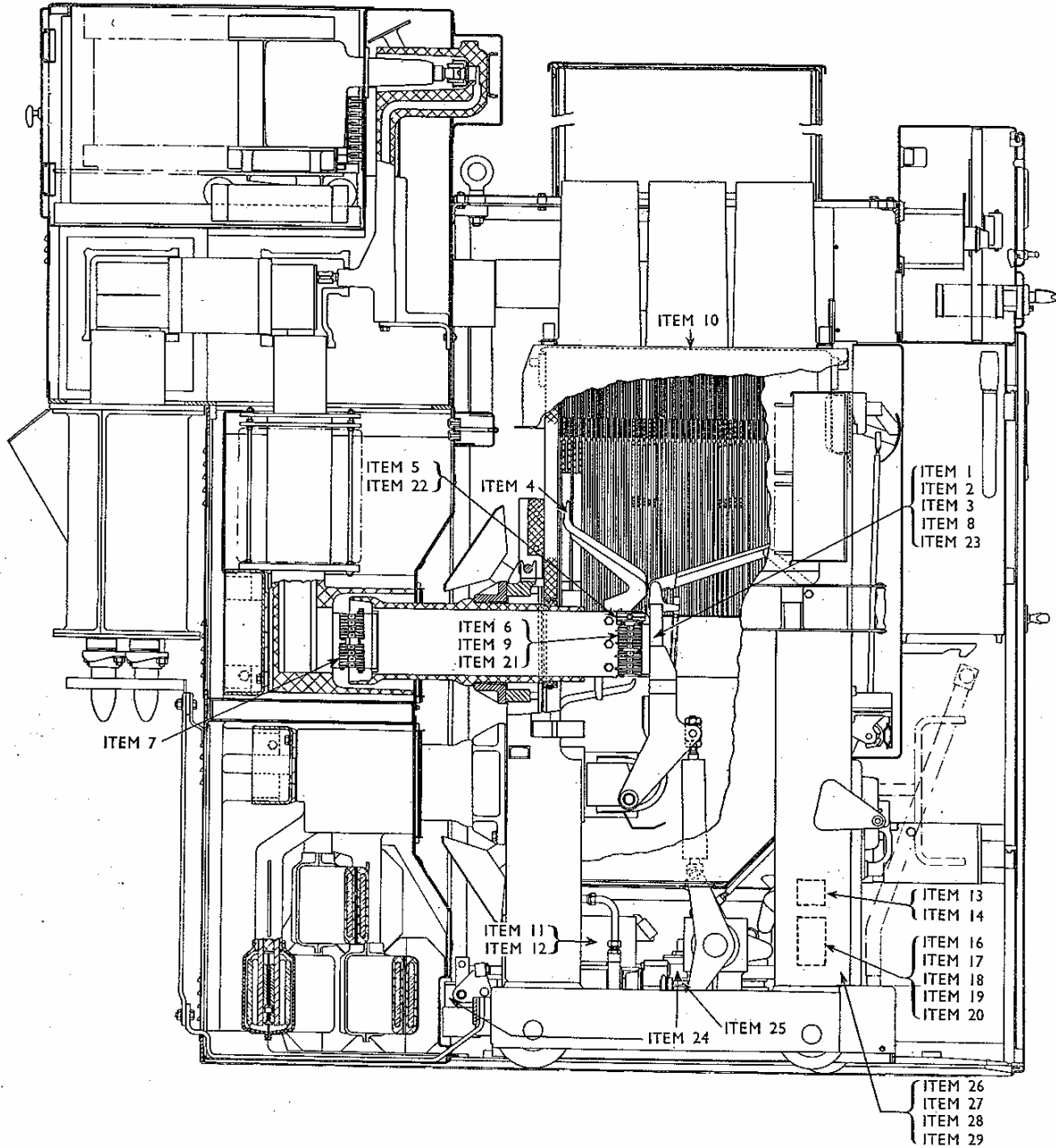

FIG. 42. A TYPICAL 11-kV 3,000 AMPERES TYPE 750 MVA PANEL ASSEMBLY.

# SIEMENS Transmission and Distribution

## REYROLLE PRODUCT SERVICES

### RECOMMENDED SPARES

| Item No. | Description                                 | Current Ratings   | Cat. No. | Total No. of panels at the current ratings shown |      |            |
|----------|---|---|----------|--|------|------------|
|          |   |   |          | 1-6  | 7-20 | 21 or more |
| 8        | Flexible connector for moving-arcng contact | All ratings up to 2000A and Neutral earthing circuit-breakers<br>2400A<br>3000A | 771A1902 | 3  | 6    | 9          |
|          |   |   | 771A1922 | 3  | —    | —          |
|          |   |   | 771A880  | 3  | —    | —          |
| 10       | Arc-chute                                   | All ratings up to 2400A and Neutral earthing circuit-breakers<br>3000A          | 771A1863 | 3  | 6    | 9          |
|          |   |   | 771A1895 | 3  | —    | —          |
| 11       | Closing coils 110V.                         | All ratings up to 2400A<br>3000A<br>and Neutral earthing circuit-breakers       | 765A805  | 1  | 2    | 3          |
|          |   |   | 771A1407 | 1  | —    | —          |
|          |   |   | 765A749  | 1  | —    | —          |
| 12       | Closing coils 240V.                         | All ratings up to 2400A<br>3000A<br>and Neutral earthing circuit-breakers       | 765A801  | 1  | 2    | 3          |
|          |   |   | 775A226  | 1  | —    | —          |
|          |   |   | 765A750  | 1  | —    | —          |
| 13       | Trip-coils 110V. d.c.                       | All ratings and Neutral earthing circuit-breakers                               | 751A946Y | 1  | 2    | 3          |
| 14       | Trip-coils 220/240V. d.c.                   | All ratings and Neutral earthing circuit-breakers                               | 751A2130 | 1  | 2    | 3          |
| 16       | Solenoid contactor-contacts                 | All ratings and Neutral earthing circuit-breakers                               | 6034A4   | 4  | 8    | 12         |
| 17       | Solenoid contactor-coils 200/240V. d.c.     | All ratings and Neutral earthing circuit-breakers                               | 603A21Y  | 2  | 4    | 6          |
| 18       | Solenoid contactor-coils 110V. d.c.         | All ratings and Neutral earthing circuit-breakers                               | 6034A28  | 2  | 4    | 6          |
| 30 to 35 | Fuses                                       | Fuses should be stocked according to type, manufacture and rating required.     |          | As required.                                     |      |            |
| 36       | Voltage-transformer primary-fuse            | All ratings with a Voltage transformer  | 395A8400 | 3  | 6    | 9          |

It should be noted that all other items on the overall spares list are generally available at short notice from Hebburn Works.

For overseas, the supplying of any of these additional spares should be by arrangement with the customer.

RECOMMENDED SPARES

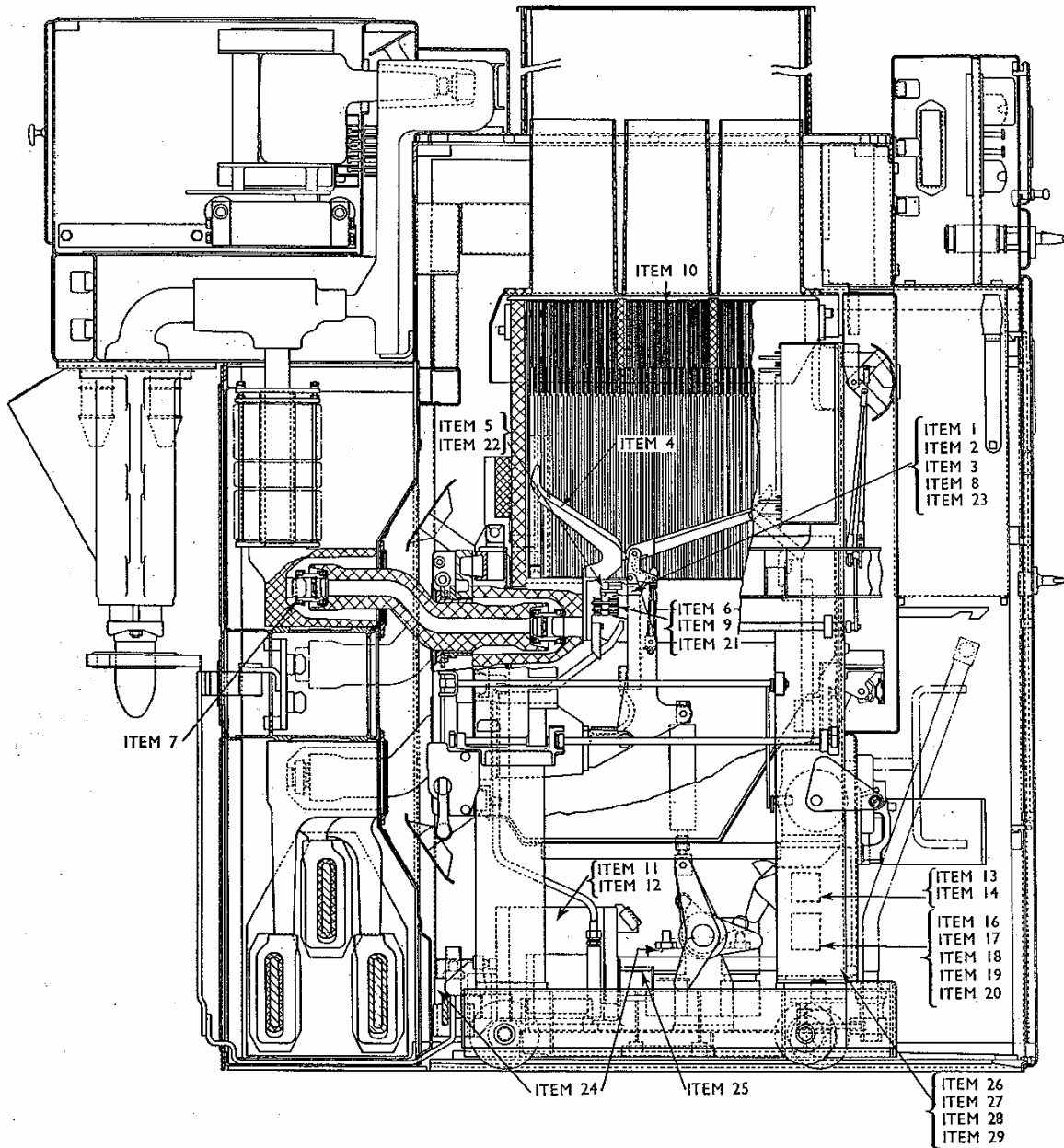

FIG. 43. A TYPICAL 11-kV 800 AMPERES 750 MVA TYPE 1136A PANEL ASSEMBLY.

# SIEMENS Transmission and Distribution

## REYROLLE PRODUCT SERVICES

---

### RECOMMENDED SPARES

#### 500 MVA AND 750 MVA

#### 2400 AMPERE AND 3000 AMPERE EARTHING SWITCHES

Recommended minimum quantities to be kept in site stores or central depot for normal routine maintenance.

| Item No. | Description                   | Cat. No. | Quantity |
|----------|-------------------------------|----------|----------|
| 1        | Main moving-contact LH        | 771A2338 | 3        |
|          | RH                            | 771A2282 | 3        |
| 2        | Main fixed-contact unit       | 771A2344 | 3        |
| 3        | Isolating-contact unit 2400A  | 771A987  | 3        |
|          | 3000A                         | 771A1535 | 3        |
| 4        | Spring-release coil 110V d.c. | 751A2444 | 1        |

# SIEMENS Transmission and Distribution

## REYROLLE PRODUCT SERVICES

---

### RECOMMENDED SPARES

---

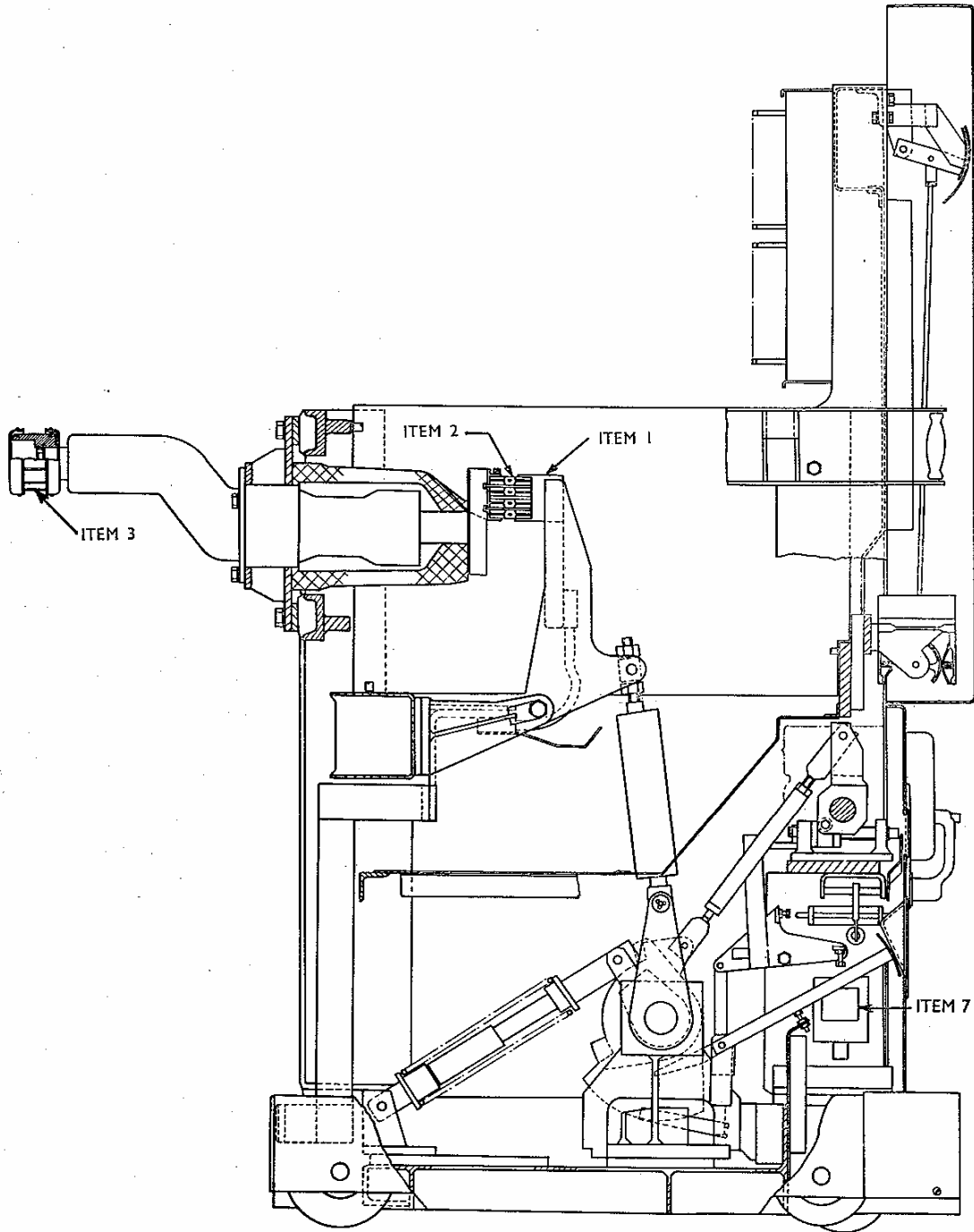

FIG. 44. A TYPICAL 2400 AMPERE 500-MVA TO 750-MVA EARTHING-SWITCH.

# SIEMENS Transmission and Distribution

## REYROLLE PRODUCT SERVICES

---

### RECOMMENDED SPARES

---

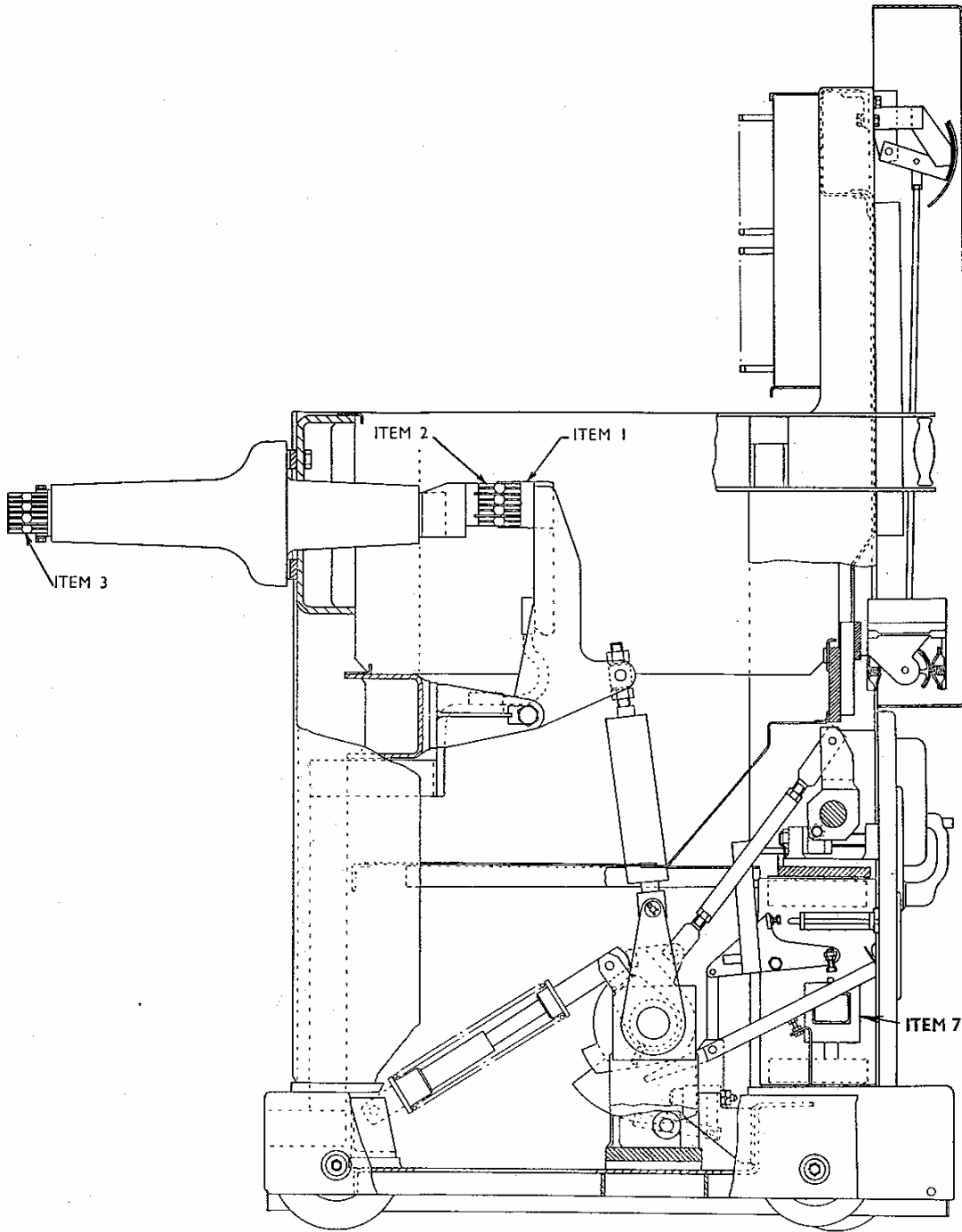

FIG. 45. A TYPICAL 3000 AMPERE 500-MVA TO 750-MVA EARTHING-SWITCH.

### **Appendix 3 – Up-rating**

It is not practical to up-rate the 500 MVA unit to 750 MVA.

It is possible to up-rate the 750 MVA unit to give an enhanced make capability of 900 MVA

### **Retrofit**

A vacuum retrofit circuit breaker is available, they can be fitted to all circuit breakers rated up to 11kV 1200A 750MVA.

On-board surge suppressors can be fitted for motor circuit applications.



Before

After Refurbishment

After Retrofit