

### TITLE

---

# Long Term Maintenance and Care for Reyrolle L800/1000T

E. C. Wright 19/07/04

This document is to be used in conjunction with Installation, Operation and Maintenance Schedule IOMS 864. Its aim is to provide guidance for owners of equipment which has been in service more than 20 years.

### Contents –

|                                                   |         |
|---------------------------------------------------|---------|
| Introduction                                      | Page 2  |
| Key Questions                                     | Page 2  |
| Condition Assessment                              | Page 3  |
| Non-Intrusive PDM                                 | Page 3  |
| Power Factor Testing                              | Page 5  |
| Dynamic Characteristics                           | Page 7  |
| Beta Arc Protection                               | Page 7  |
| Recommended Care Program                          | Page 10 |
| Spares for Maintenance                            | Page 10 |
| Spares for Extended Service                       | Page 10 |
| Factory Based Overhaul                            | Page 10 |
| Factory Based Rebuild-Refurbishment               | Page 10 |
| Recommendation for Life Extension                 | Page 11 |
| New Cable Box Designs for Polymeric Cables        | Page 12 |
| Appendix 1 – Recommended Maintenance Regime       | Page 13 |
| Appendix 2 – Maintenance Spares                   | Page 14 |
| Appendix 3 – Mechanism Spares for High Operations | Page 15 |

# SIEMENS Transmission and Distribution

## REYROLLE PRODUCT SERVICES

---

### ***Introduction***

During normal every day operation, switchgear works well within its design envelope and therefore, even after many years of service, appears superficially to be OK.

**Fault clearance however may require the equipment to work at near maximum performance and substandard equipment will be susceptible to significant damage.**

To maintain rating capability key components/functions must be in good operational condition:

**The above does not indicate that the product has a limited lifespan, in fact the L800T range has proven to be very reliable when well looked after.**

We can actually take advantage of the sub-station history of older equipment to design bespoke maintenance, which will not only extend the working life but will reduce the chance of catastrophic damage and can even reduce maintenance costs.

The owner of older equipment (20 years and beyond) should have the information which will allow him to design a maintenance plan to suit his needs. This document will help with that process.

### ***Key Questions***

1. How often is the equipment switched?
2. Is this switching duty at full rated current or well below rated current?
3. How often does the system see a fault?
4. What environmental conditions exist within the sub-station? – Is the switchgear dirty or damp or both? (we are concerned here mainly with the primary insulation)
5. Do we know the condition of the primary functional systems of the switchgear –
  - a. Primary Insulation.
  - b. Contacts, Turbulators and Oil.
  - c. The dynamic operating characteristics of mechanism and contacts.

Points 1 to 4 should be available from historical records and we will look later how we will use this information.

Point 5 is actually our recommended starting point. We feel it is logical to make a condition assessment of the equipment, and instigate any repairs prior to introducing a new maintenance regime. Using the condition assessment approach at suitable intervals will also help ensure full rating capability is maintained.

# SIEMENS Transmission and Distribution

## REYROLLE PRODUCT SERVICES

### Condition Assessment

#### Recommended site testing For condition assessment of Reyrolle L800/1000T

Pf Testing of Capacitor Bushings



Speed Curving - In house electronic system  
Using original test parameters.



Non-intrusive Discharge



### Non-intrusive Discharge Monitoring.

Discharge monitoring is recommended to identify any possible deterioration of filled joints such as the shrouds in the Busbar and Transformer Chambers, surface discharges on primary insulation and similar possible sources.

The system used is non-intrusive. Magnetic probes are attached to the outer skin of the switchgear and are designed to pickup magnetic wave pulses, a phenomenon of electrical discharge. Each probe will pick up a source of discharge but the monitor can determine by time of flight which probe is closest to the source. (see diagrams below) The monitor sweeps the probes approximately every 5 minutes over a period (usually one week) and therefore can determine if the problem is constant, the level and therefore the severity. Recommendations will be given.

Owners of the switchgear can be shown how to transfer monitoring equipment from one board the next and e-mail information to ourselves for analysis.

# SIEMENS Transmission and Distribution

## REYROLLE PRODUCT SERVICES

### Partial Discharge Monitoring

SIEMENS

- Charge transferred from HV busbar to earthed enclosure.
- EM waves emanate away from the discharge site.
- EM waves escape through joint in the enclosure and sweep across the surface of the switchgear.
- EM wave detected by the P.D.M.

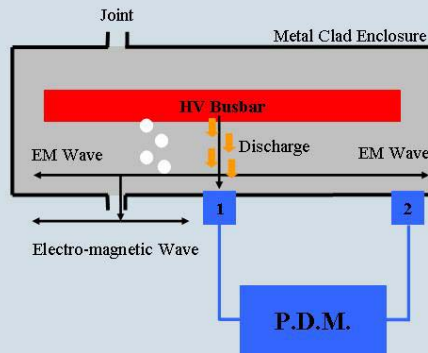

Feb-08

ed.wright@siemens.com T&D/UK/Product Services

11

### Partial Discharge Monitoring

SIEMENS

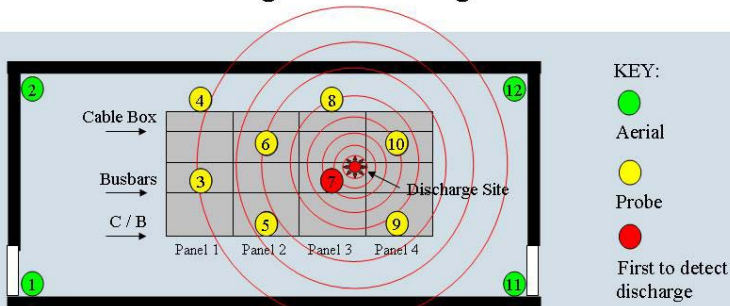

Typical monitoring set-up within a substation (plan view)

- All of the probes detect the discharge from every discharge site on the board.
- The monitor allocates the discharge to the probe at which the discharge arrives first.
- Aerials detect background noise first. Background noise is allocated to aerials.
- The monitor can detect multiple discharge sites within the switchboard.

Feb-08

ed.wright@siemens.com T&D/UK/Product Services



12

Our report gives graphical information, explanation and recommendation for repair. Part of the graphical information from a recent report is shown below.

# SIEMENS Transmission and Distribution

## REYROLLE PRODUCT SERVICES

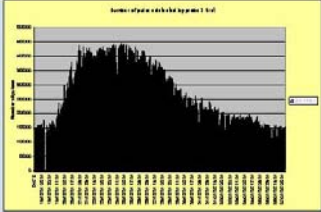
### Partial Discharge Monitoring



This is a graph from one of our recent surveys. The probe is situated on a cable box. This discharge was active constantly at a dangerously high level. As we can see below, the discharge was getting worse as time went on.

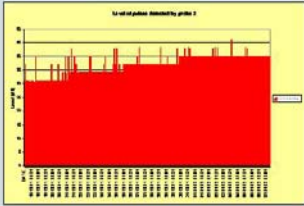



The primary insulation involved here would certainly have failed in the near future if left unattended. An unplanned outage would have cost this particular customer around £300,000 a day. This problem would have gone unnoticed if not for the customer requesting a PDM survey. The cable box was successfully repaired in the shortest time possible. Subsequent PDM surveys have given 'discharge free' results.

Feb-08 ed.wright@siemens.com T&D/UK/Product Services 13

### Power Factor (TAN DELTA) Testing

L800T like many other switchgears designed at the same time or earlier employed paper insulated bushings in primary circuits. These bushings designated as SRBP or ERIP type bushings have technical advantages when compared to the more modern and cheaper cast resin bushings. The advantage is shown diagrammatically below.

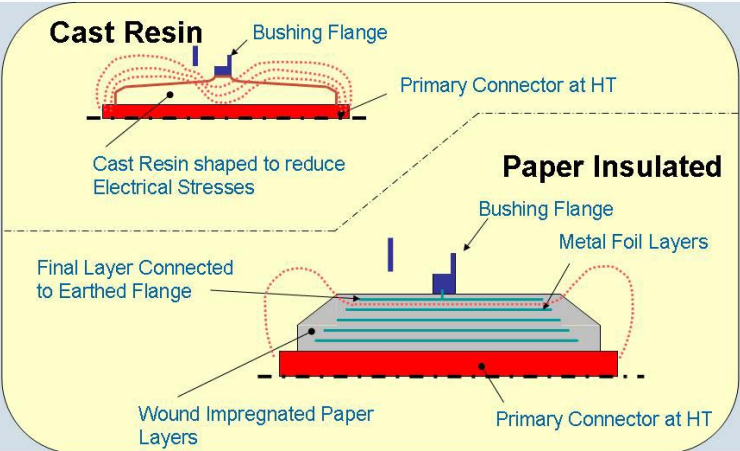
### Bushing Design



**Cast Resin**  
Bushing Flange  
Primary Connector at HT  
Cast Resin shaped to reduce Electrical Stresses

**Paper Insulated**  
Bushing Flange  
Metal Foil Layers  
Final Layer Connected to Earthed Flange  
Wound Impregnated Paper Layers  
Primary Connector at HT

Feb-08 ed.wright@siemens.com T&D/UK/Product Services 8

The metal foil capacitive layers of these bushing, smooth out the electrical stresses and therefore reduce the chances of electrical discharges.

# SIEMENS Transmission and Distribution

## REYROLLE PRODUCT SERVICES

---

However the paper windings of the bushings can become susceptible with age to moisture ingress or delaminating.

Discharge testing may not pick up longer term deterioration of the insulation.

The failure modes of these bushings, moisture ingress or conversely drying out, can take a long time to develop. Discharge testing may only pick this up as the failure is well advanced. - obviously too late!

The L800 paper insulated bushings have built in test points, which with the aid of specialist test equipment, allows us to measure some of the fundamental ac characteristics of its insulation system.

Comparing the readings obtained for pf, capacitance, charging current and resistance, against our database for new, maintained or refurbished bushings, allows us to make an informed assessment of condition.

Typically we should be able to see if there is deterioration and how advanced, therefore avoiding catastrophic failure.

In most cases bushings can be repaired and therefore the life expectancy of the switchgear is increased dramatically.

### **Dynamic Contact and Mechanism Characteristics**

When a circuit breaker design passes its short circuit and mechanical operations type tests, certain dynamic characteristics are recorded and used as a profile in all subsequent routine production tests. In other words every production circuit breaker should have the same rating capability. A typical speed curve is shown below.

# SIEMENS Transmission and Distribution

## REYROLLE PRODUCT SERVICES

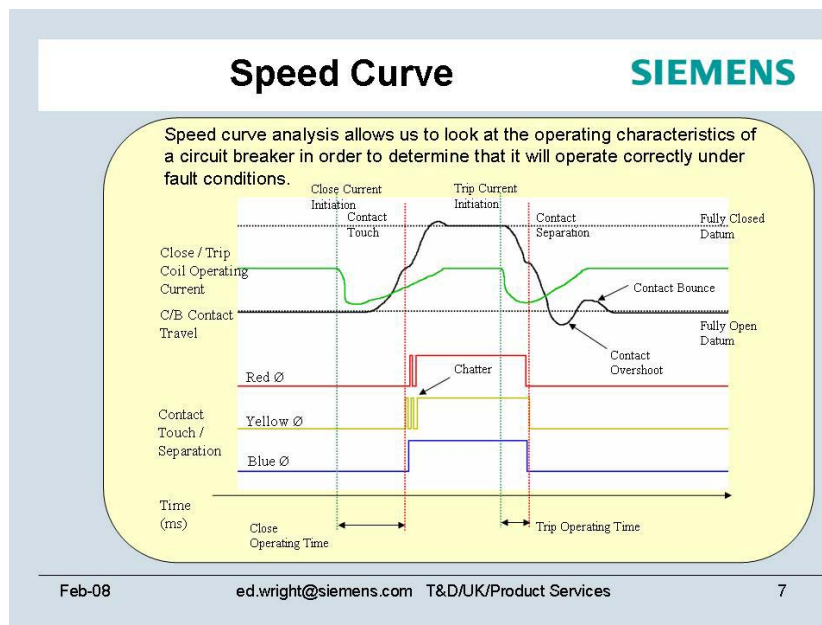

The above test combined with visual inspection of Contacts and Turbulators plus resistance and Oil tests will confirm rating capability.

Oil analysis should measure –

- Breakdown Strength
- Moisture Content
- Acidity

### **BETA ARC FAULT PROTECTION**

In the early 1990's the requirement for Internal Arc Protection on all new Primary Switchgear designs became part of IEC and UK EATS specifications.

The driver for introducing this was of course safety for the operator.

Adding design features to cope with the specification is relatively straight forward when starting a new product design. However retrofitting the capability on existing designs is generally not viable.

The advent of the BETA protection device gives us a viable method of achieving the IEC Arc Fault criteria as a retrofit solution on old air insulated chambers.

As a bonus, BETA not only gives enhanced operator safety, but it dramatically reduces the possibility of collateral damage – Faults will be contained in chamber of origin.

BETA protection can be used to protect the following S36A chambers –

- Circuit Breaker
- Busbar
- Current Transformer
- Air insulated cable boxes. (cable boxes may be compound filled)

# SIEMENS Transmission and Distribution

## REYROLLE PRODUCT SERVICES



The principle of BETA operation is shown below.



### Services Available – BETA arc prot'n

#### FEATURES

- Busbar protection primarily for distribution air insulated switchgear
- Arc detected by strong light and tripping supervised by overcurrent elements
- Fast operating time, typically 7ms, minimizes damage caused by a busbar fault
- Simple modular construction scalable for different busbar arrangements
- Full self supervision for improved reliability
- Easy to install and commission



**Internal Arc Tests**  
Carried out on a three Panel Board of LMT, fitted with BETA, were all cleared within 50ms.  
Because of the short clearance time, damage was minimal.

#### Beta - principle of operation

Incoming CB tripped if Arc & Over Current detected Simultaneously

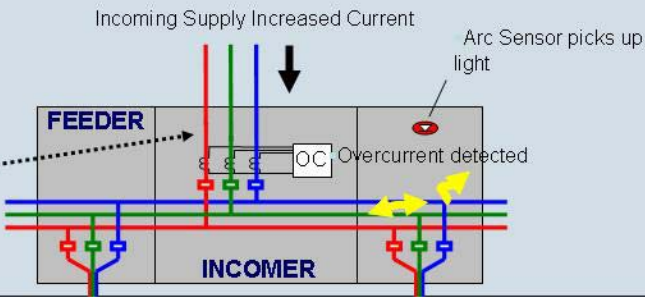

Incoming Supply Increased Current

Arc Sensor picks up light

OC Overcurrent detected

**FEEDER**

**INCOMER**

Feb-08ed.wright@siemens.com T&D/UK/Product Services9

# SIEMENS Transmission and Distribution

## REYROLLE PRODUCT SERVICES

---

### VA TECH REYROLLE PRODUCT SERVICES

#### REPAIRS, OVERHAUL, REFURBISH L800/1000T

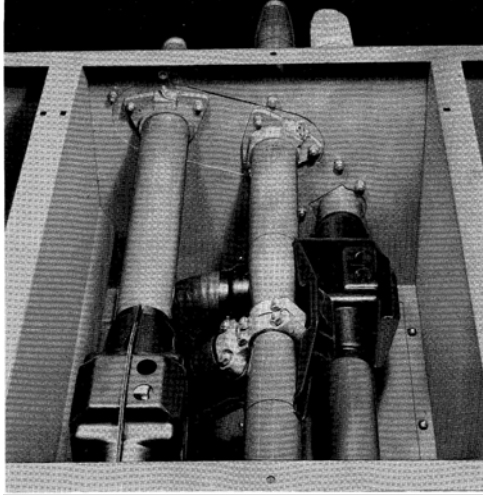

#### Recommended Enclosure Site Tests

- Discharge Monitoring
  - General insulation health check.
- Pf testing
  - Key check for busbar, CT, Orifice & CB insulators.

### VA TECH REYROLLE PRODUCT SERVICES

#### REPAIRS, OVERHAUL, REFURBISH L800/1000T

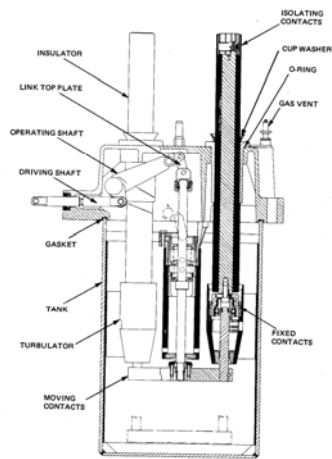

#### Recommended site checks

- Pf test for insulators.
- Check oil condition.
- Check condition of contacts.
- Check condition of Turbulators.
- Speed Curve tests.

# SIEMENS Transmission and Distribution

## REYROLLE PRODUCT SERVICES

---

### ***Recommended Care Program – Appendix 1***

As suggested earlier an alternative program of care to that shown in IOMS 864 should be introduced when the equipment has been in service longer than 20 years.

### ***Spares for normal maintenance needs – Appendix 2***

These spares are recommended for the normal wear and aging of the equipment.

### ***Spares for Mechanisms with Extended Service – Appendix 3***

Experience has shown that these additional spares should be available for mechanisms subjected to high operations.

### ***Factory based Overhaul***

When site based maintenance procedures cannot achieve consistent and correct circuit breaker operation. Our factory based overhaul service is designed to bring a circuit breaker back to full rating capability with the minimum work. This is achieved by a process of an initial test and inspection to establish work to be done and an agreement with the customer to proceed.

Traveler circuit breakers can be made available to reduce outage times.

### ***Factory based Rebuild-Refurbishment***

This process described below is recommended for circuit breakers older than 25 years. The process is a complete rebuild with replacement of key components and wiring which achieves an almost “As New” result. The end result not only re-establishes rating but dramatically extends the working life of the equipment.

# SIEMENS Transmission and Distribution

## REYROLLE PRODUCT SERVICES

### L800/1000T Refurbishment

SIEMENS

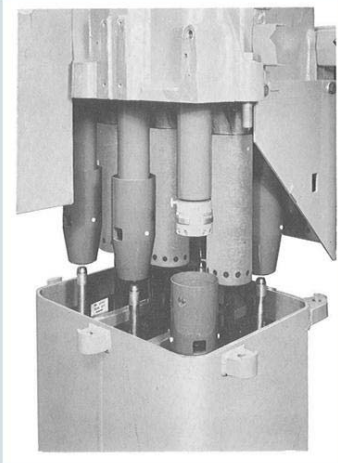

#### REFURBISHMENT

- ⇒ Increase Life
- ⇒ Traveler CB's
- ⇒ Fast Turn Round

#### REFURBISHMENT SCOPE OF WORK.

- ⇒ Pre-work CB Inspection & Test
- ⇒ Oil Testing,
- ⇒ Internal Inspection,
- ⇒ Full Strip Down To Carcass,
- ⇒ 100% Component Inspection,
- ⇒ Replacement of All springs,
- ⇒ Rebuild & Rewire,
- ⇒ Re-Test.

Feb-08

ed.wright@siemens.com T&D/UK/Product Services

2

### L800/1000T Extension Panels

SIEMENS

Refurbished CB's & Enclosures to be used For L42T Board extension.



Bus Bar Trunk manufactured from New to connect L800 to L42

Panels and CB's fully Refurbished From our stock of recovered equipment.

Feb-08

ed.wright@siemens.com T&D/UK/Product Services

3

### ***Recommendation to achieve Life Extension and Low Cost of Ownership.***

The process recommended in Appendix 1, a combination of Refurbishment, Condition Assessment and Bespoke Maintenance will extend the working life of the equipment. The logic of this is shown diagrammatically below. The process of targeted or bespoke maintenance also has the potential to reduce maintenance cost.



# SIEMENS Transmission and Distribution

## REYROLLE PRODUCT SERVICES

- Pfisterer system using existing cable box body with new gland plates

### L42/45T Design Enhancement

SIEMENS

Polymeric Cable - Existing  
Cable Box!

Suitable for L800/L42T existing  
Cable Boxes - Oil filled

New Gland Plate with Pfisterer  
female insulator

Polymeric cable with Pfisterer  
male connector

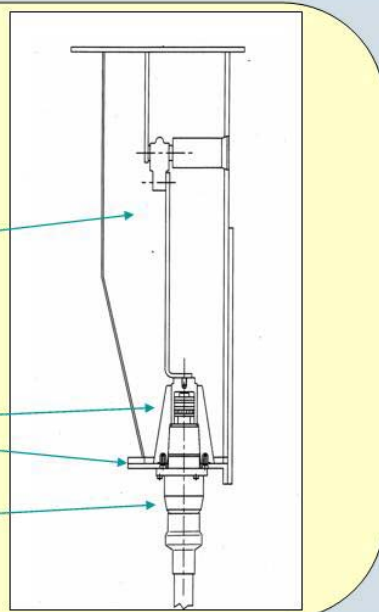

Feb-08

ed.wright@siemens.com T&D/UK/Product Services

6

# SIEMENS Transmission and Distribution

## REYROLLE PRODUCT SERVICES

### APPENDIX 1 – Recommended Maintenance Regime for L800/1000T in service over 20 years.

| Interval                                                                                         | Circuit Breaker                                                                                                  | Enclosure                                                                                  |
|--------------------------------------------------------------------------------------------------|------------------------------------------------------------------------------------------------------------------|--------------------------------------------------------------------------------------------|
| 25 years                                                                                         | Rebuild Refurbishment                                                                                            | Discharge Monitoring<br>Pf testing                                                         |
| 8 year                                                                                           | Discharge Monitoring<br>Pf testing<br>Speed Curve<br>Internal Tank Inspection<br>Oil Test<br>Clean and Lubricate | Discharge Monitoring<br>Pf testing<br>Clean and Lubricate<br>Touch-up paint if necessary   |
| 4 year – Only required for poor environments<br><br>(8 year report may suggest additional tests) | Clean and Lubricate<br><br>(Discharge Monitoring<br>Pf testing)                                                  | Clean and Lubricate<br>Touch-up paint if necessary<br>(Discharge Monitoring<br>Pf testing) |
| Every 2000 operations at low system current.                                                     | Clean, lubricate and inspect mechanism.                                                                          |                                                                                            |
| Every 2000 operations at high system current.                                                    | Clean, lubricate and inspect mechanism.<br>Internal Tank Inspection<br>Oil Test.                                 |                                                                                            |
| After Fault                                                                                      | Internal Tank Inspection                                                                                         |                                                                                            |
| Yearly if CB not operated                                                                        | Electrical Close & Trip several times.                                                                           |                                                                                            |

# SIEMENS Transmission and Distribution

## REYROLLE PRODUCT SERVICES

---

### APPENDIX 2 – Maintenance Spares

#### L800T/X4/MO 33kV 1250A

| Description                              | Article No. | Quantity<br>1-6 Panels | Quantity<br>7-12 Panels | Quantity<br>13 or<br>More |
|------------------------------------------|-------------|------------------------|-------------------------|---------------------------|
| Turbulator                               | 891A1099Y   | 6                      | 12                      | 12                        |
| Turb/Vent locking plates                 | 891A1136    | 6                      | 6                       | 6                         |
| Fixed Cluster Contact                    | 891A1102    | 6                      | 6                       | 6                         |
| Fixed Arcing Contact Segment             | 891A1095    | 6                      | 12                      | 12                        |
| Fixed Main Contact Segment               | 801A732     | 18                     | 36                      | 36                        |
| Moving Contact Complete                  | 891A596     | 6                      | 12                      | 12                        |
| Closing Solenoid Coil<br>(220/240v dc) * | 895A729Y    | 2                      | 2                       | 3                         |
| Trip Coil<br>(110v dc) *                 | 895A821     | 2                      | 2                       | 3                         |
| Motor<br>(220/240v dc) *                 | 891A1205    | 1                      | 1                       | 1                         |
| Tank Gasket                              | 891A712     | 2                      | 4                       | 6                         |
| Isolating Contacts                       | 891A685     | 6                      | 6                       | 6                         |
| Contacto<br>(110v dc) *                  | 975A852Y    | 2                      | 2                       | 3                         |
| VT Fuse with Adaptor                     | 2741-49338E | 3                      | 6                       | 12                        |

#### L1000T/X2/MO 33kV 2000A

| Description                              | Article No. | Quantity<br>1-6 Panels | Quantity<br>7-12 Panels | Quantity<br>13 or<br>More |
|------------------------------------------|-------------|------------------------|-------------------------|---------------------------|
| Turbulator                               | 891A1112Y   | 6                      | 12                      | 12                        |
| Turb/Vent locking plates                 | 891A1136    | 6                      | 6                       | 6                         |
| Fixed Cluster Contact                    | 891A1102    | 6                      | 6                       | 6                         |
| Fixed Arcing Contact Segment             | 891A1095    | 6                      | 12                      | 12                        |
| Fixed Main Contact Segment               | 801A732     | 18                     | 36                      | 36                        |
| Moving Contact Complete                  | 891A596     | 6                      | 12                      | 12                        |
| Closing Solenoid Coil<br>(220/240v dc) * | 895A785     | 2                      | 2                       | 3                         |
| Trip Coil<br>(110v dc) *                 | 895A821     | 2                      | 2                       | 3                         |
| Motor<br>(220/240v dc) *                 | 891A1207    | 1                      | 1                       | 1                         |
| Tank Gasket                              | 891A927     | 2                      | 4                       | 6                         |
| Isolating Contacts                       | 891A1091    | 6                      | 6                       | 6                         |
| Contacto<br>(110v dc) *                  | 975A852Y    | 2                      | 2                       | 3                         |
| VT Fuse with Adaptor                     | 2741-49338E | 3                      | 6                       | 12                        |

# SIEMENS Transmission and Distribution

## REYROLLE PRODUCT SERVICES

---

### APPENDIX 3 – Mechanism Spares for high operations units.

#### L800T/X4/MO 33kV 1250A

| Description           | Article No. | Quantity |
|-----------------------|-------------|----------|
|                       |             | 4 kits   |
| Tension Spring        | 865A22      | 4        |
| Torsion Spring        | 865A376     | 4        |
| Roller Latch Assembly | 865A975     | 4        |
| Trip Latch            | 865A1038X   | 4        |
| Links                 | 865A1087    | 8        |
| Pin                   | 865A1114    | 4        |
| Eccentric Stop        | 865A1398    | 4        |
| Plunger Shaft         | 865A1485    | 4        |
| Schnorr Disc Spring   | 2117-80231J | 4        |

#### L1000T/X2/MO 33kV 2000A

| Description    | Article No. | Quantity |
|----------------|-------------|----------|
|                |             | 4 kits   |
| Tension Spring | 865A22      | 4        |
| Roller Latch   | 865A673     | 4        |
| Bearing        |             | 4        |
| Trip Latch     | 865A666     | 4        |
| Links          | 865A669     | 8        |
| Eccentric Pin  | 865A651     | 4        |
| Plunger        | 865A793     | 4        |